



X-RAY on my desk

VEGARAY

X-Ray 촬영 이미지 참조 & 베가레이 소개

X-RAY on my desk

VEGARAY

X-Ray for PCB

* 베가레이 엑스레이 vs. 3D CT 비교 – PCB void

- ✓ 동일 위치에서 거의 비슷한 크기의 void 확인 가능
- ✓ CT 슬라이스 이미징에 최소 20분 이상 시간 소요되지만 베가레이 엑스레이는 4초면 충분
- ✓ 2D 엑스레이 레이어 겹침 현상 감안하면 가성비, 공간절약, 시간 절약 등의 측면에서 베가레이 장점 多

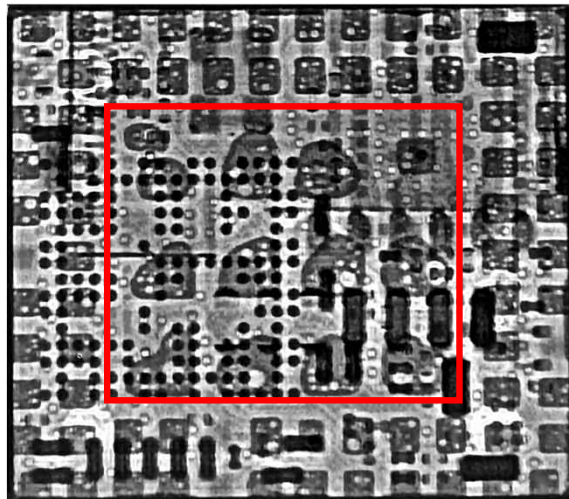
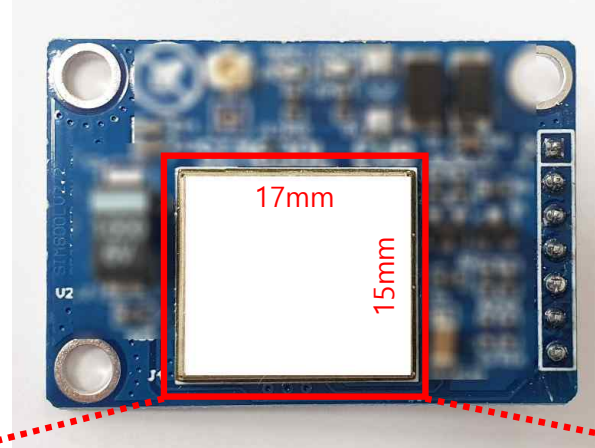

베가레이 2D 엑스레이

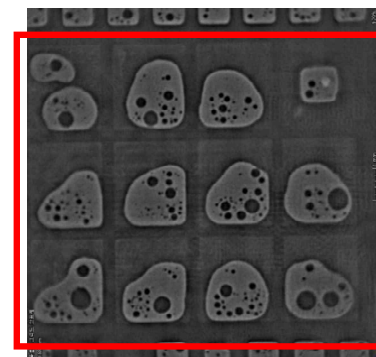

3억원 짜리 장비 3D CT이미지
(슬라이스 단면)

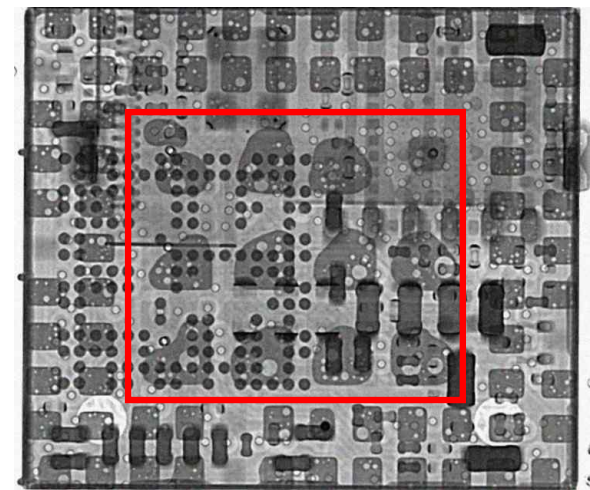

3억원 짜리 장비 2D 엑스레이 이미지

* 베가레이 엑스레이 촬영 이미지 - IC chip 페이크 부품 검사

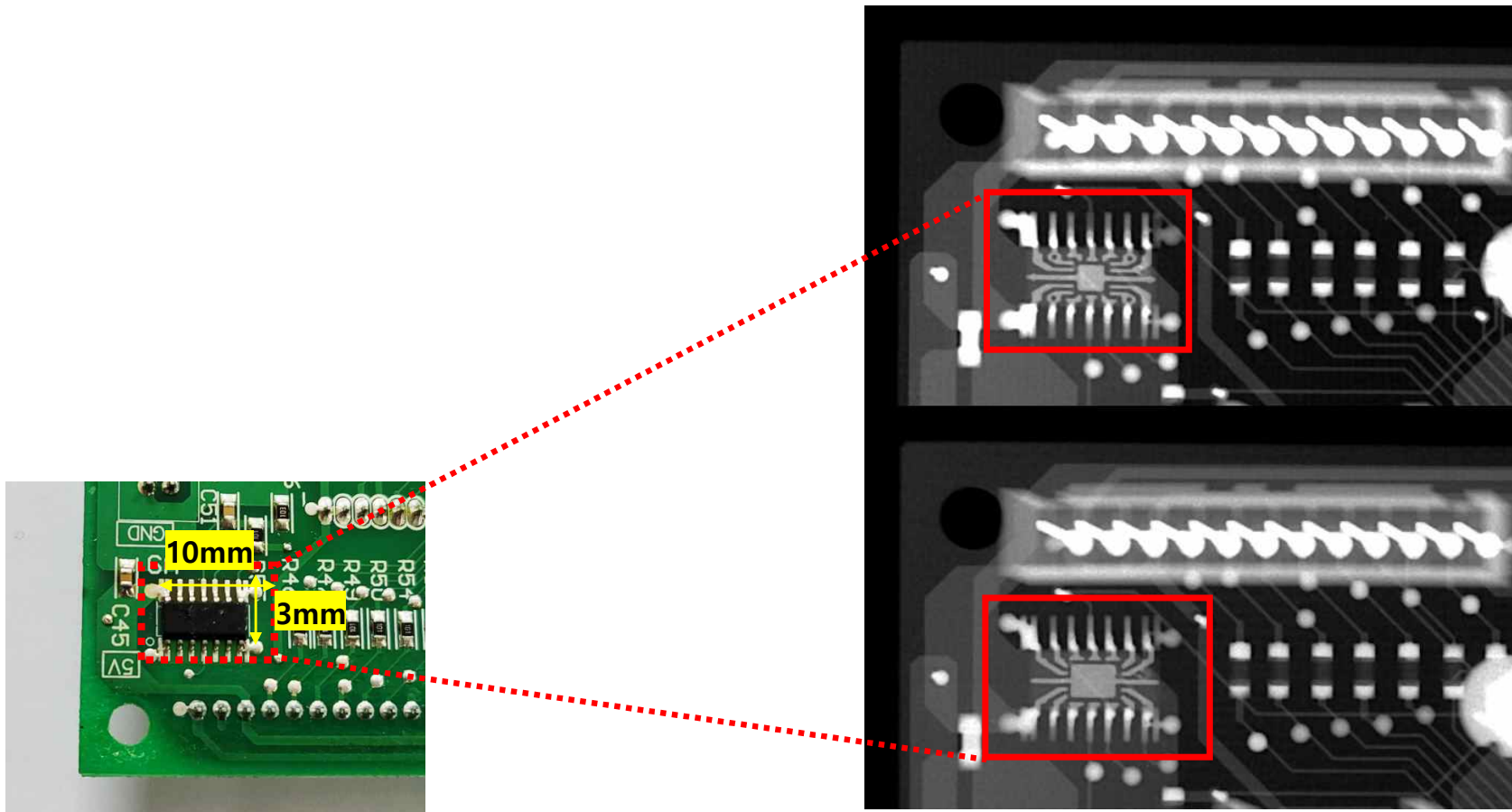

* 베가레이 엑스레이 촬영 이미지 - IC chip

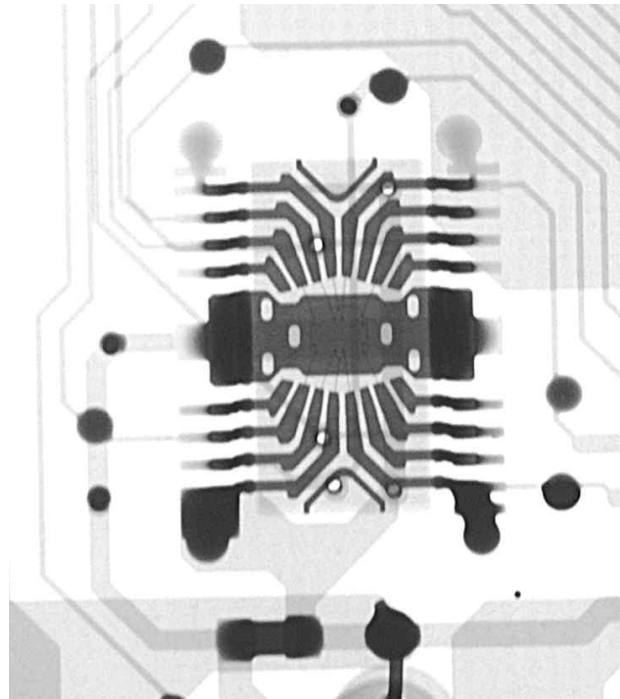

* 베가레이 엑스레이 촬영 이미지 - PCB 불량 확인(쇼트)

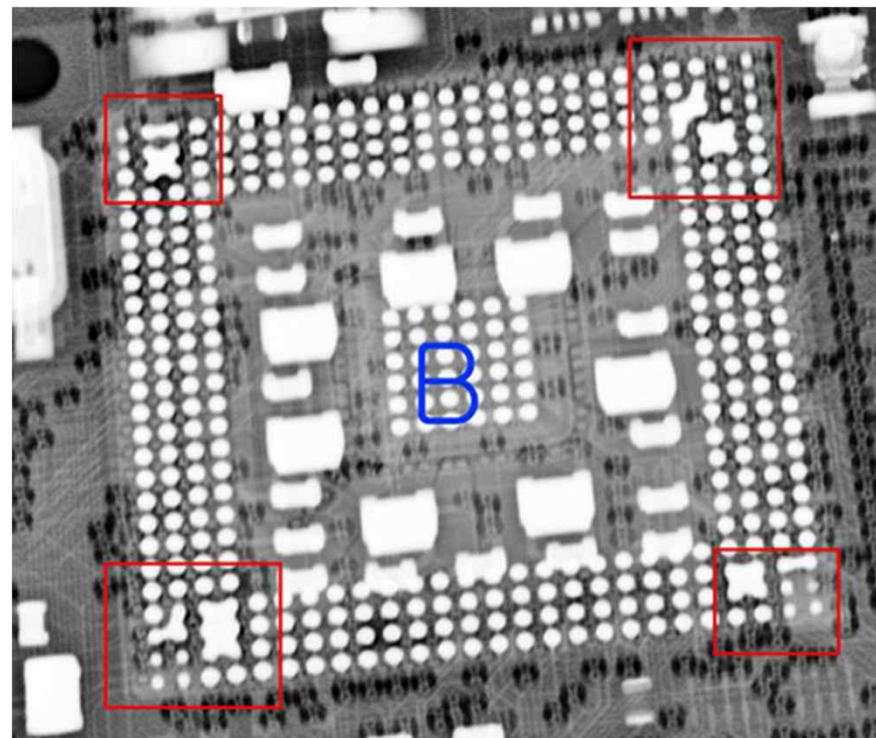
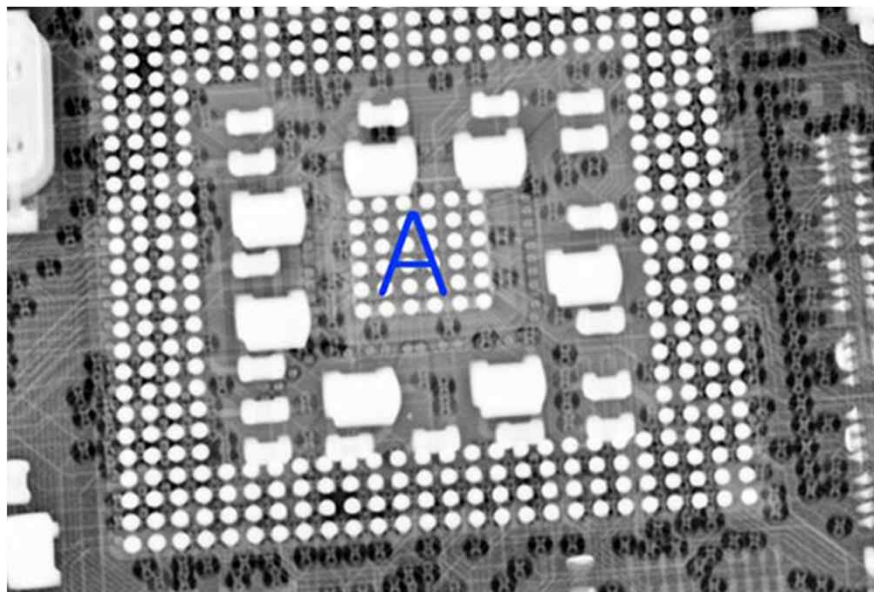

* 베가레이 엑스레이 촬영 이미지 - IC chip

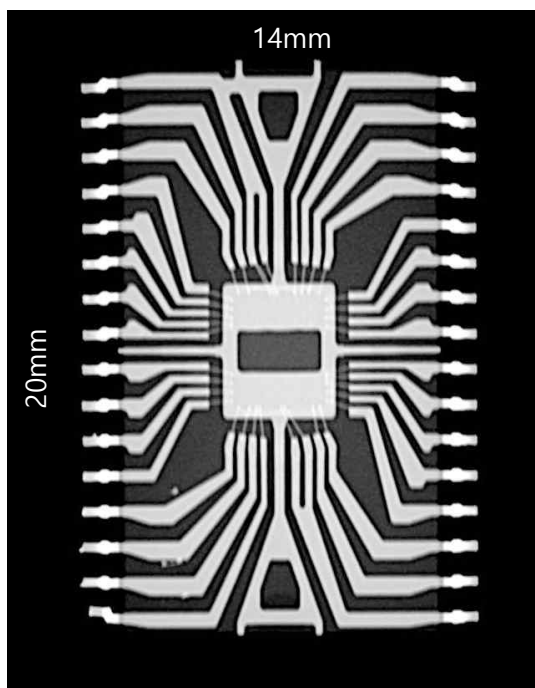

* 반전 이미지

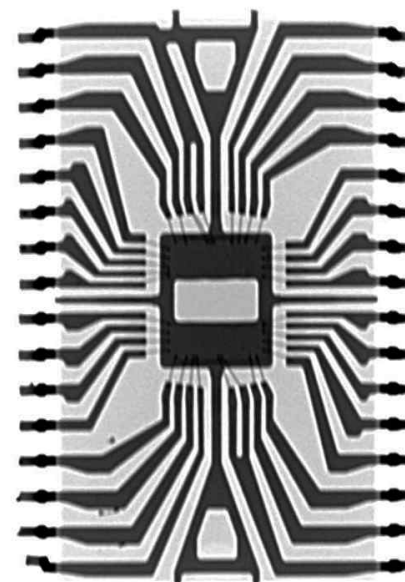

* 베가레이 엑스레이 촬영 이미지 - IC chip

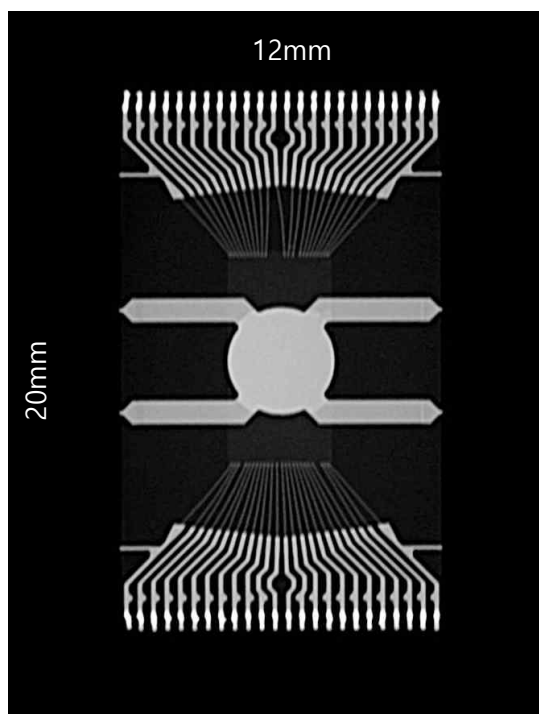

* 반전 이미지

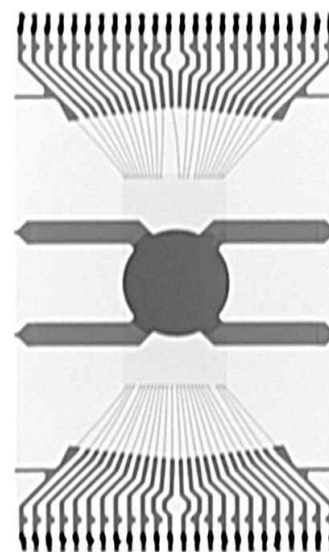

* 베가레이 엑스레이 촬영 이미지 - TQFP chip

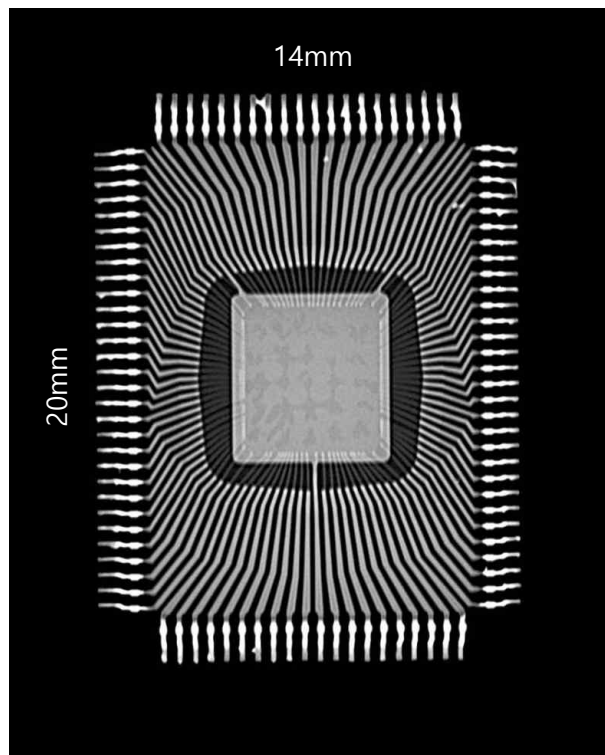

* 반전 이미지

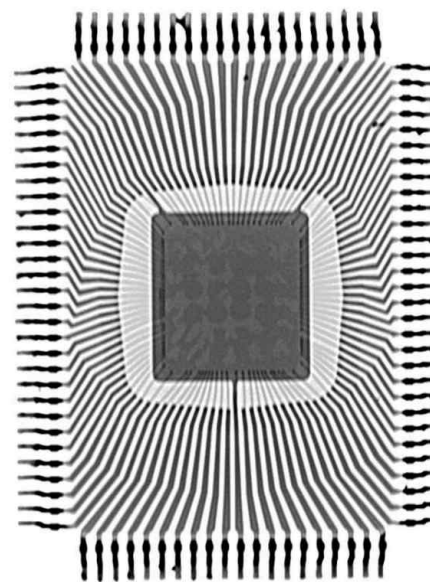

X-Ray for Smartphone & components

* 베가레이 촬영 이미지 - 스마트폰(갤럭시 Z Flip 3 & 4 비교 이미지)

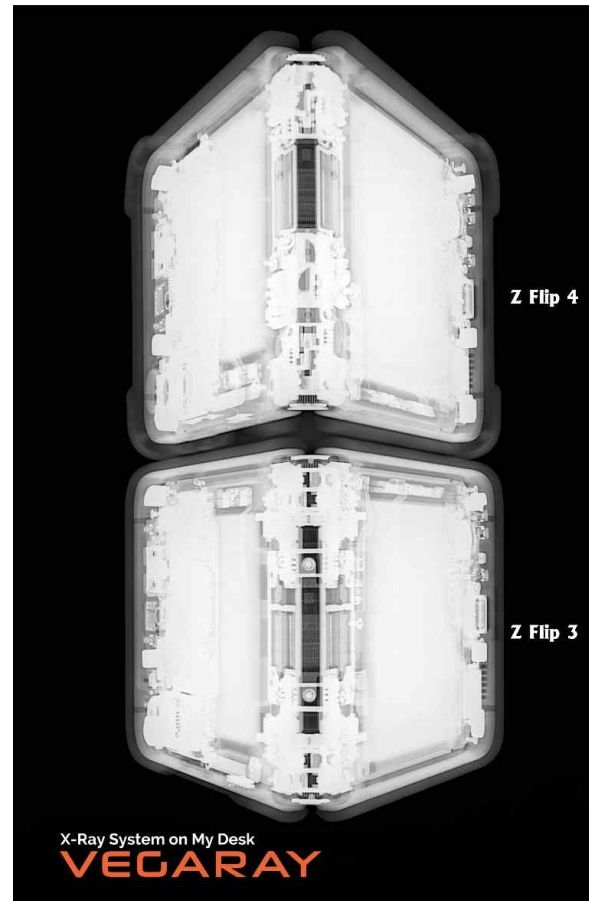
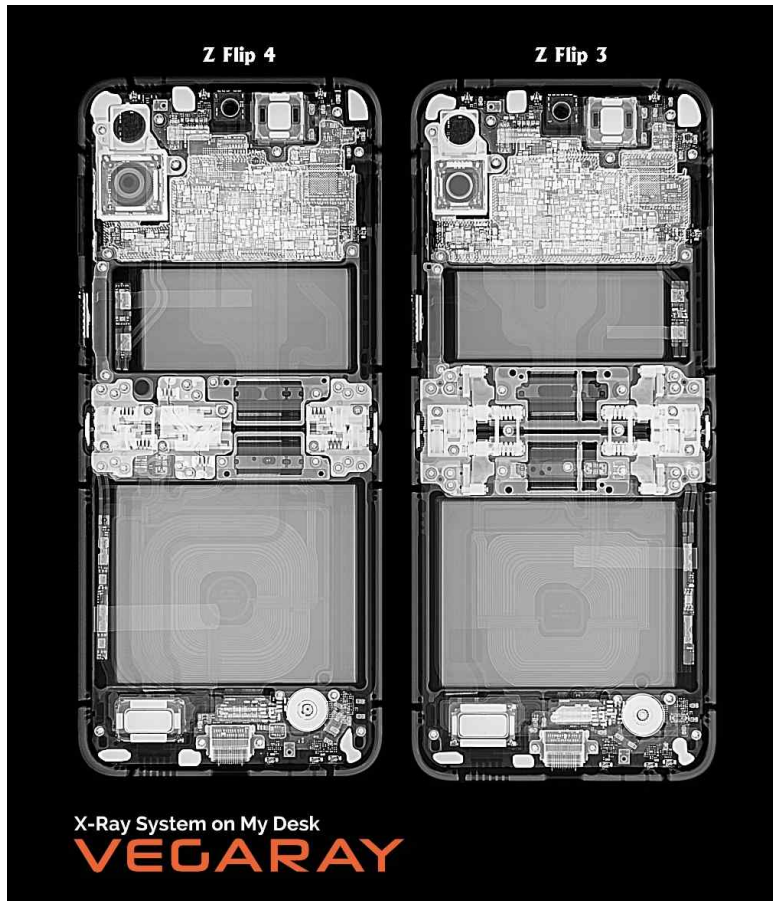

* 베가레이 촬영 이미지 - 스마트폰(갤럭시노트20 울트라) & 갤럭시노트 펜

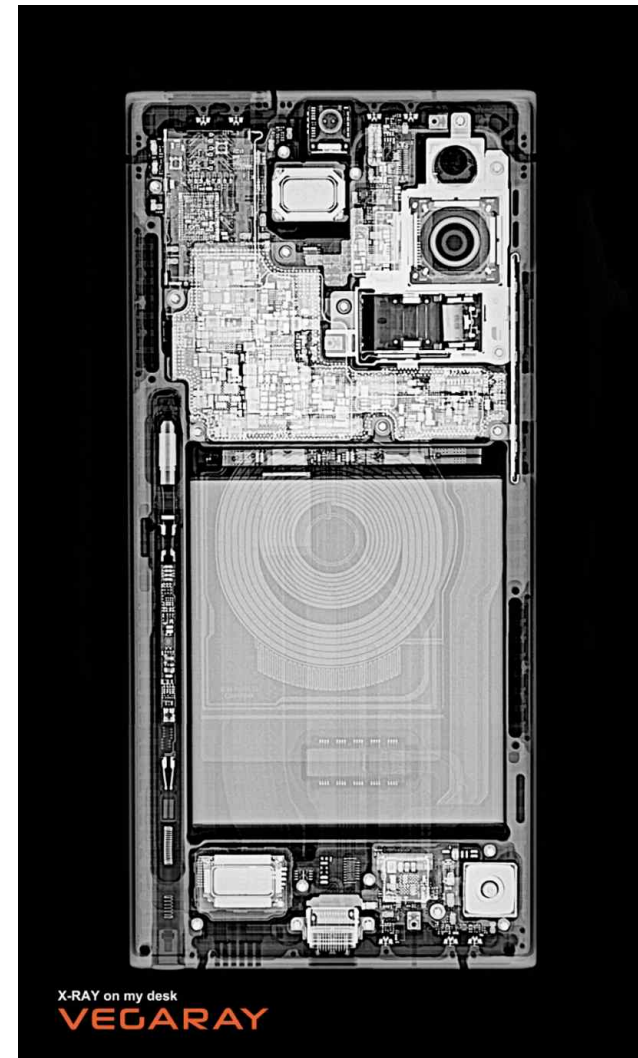

* 베가레이 촬영 이미지 - 스마트폰(갤럭시S20)

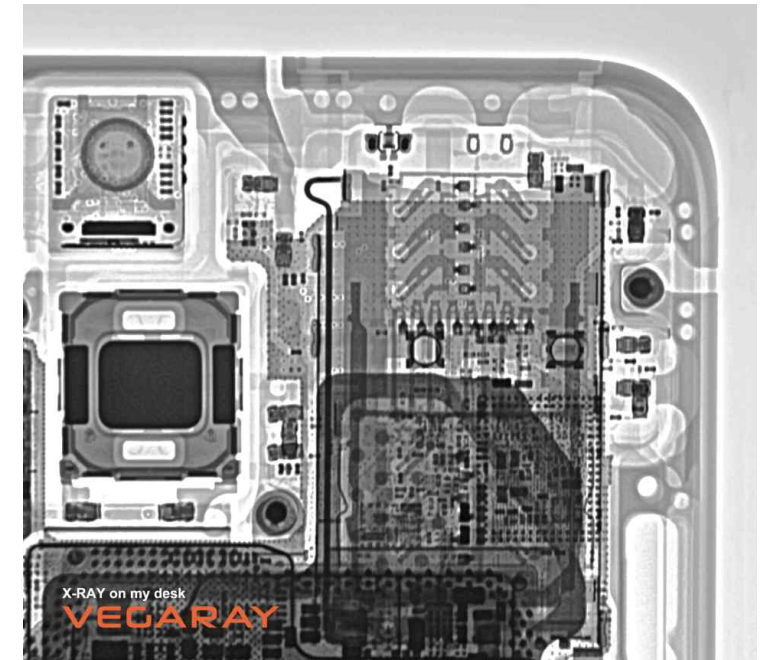
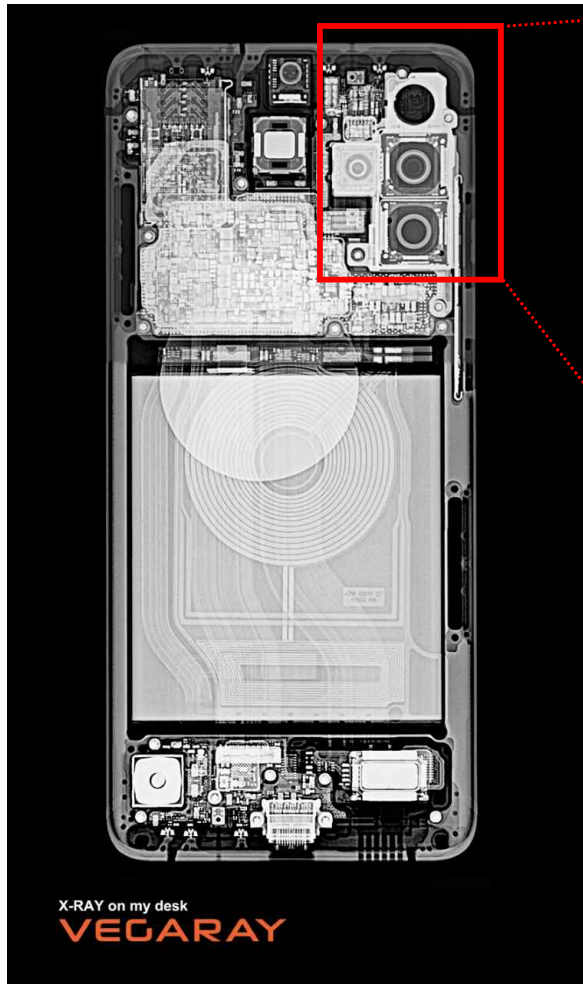

* 베가레이 촬영 이미지 - 스마트폰 부품

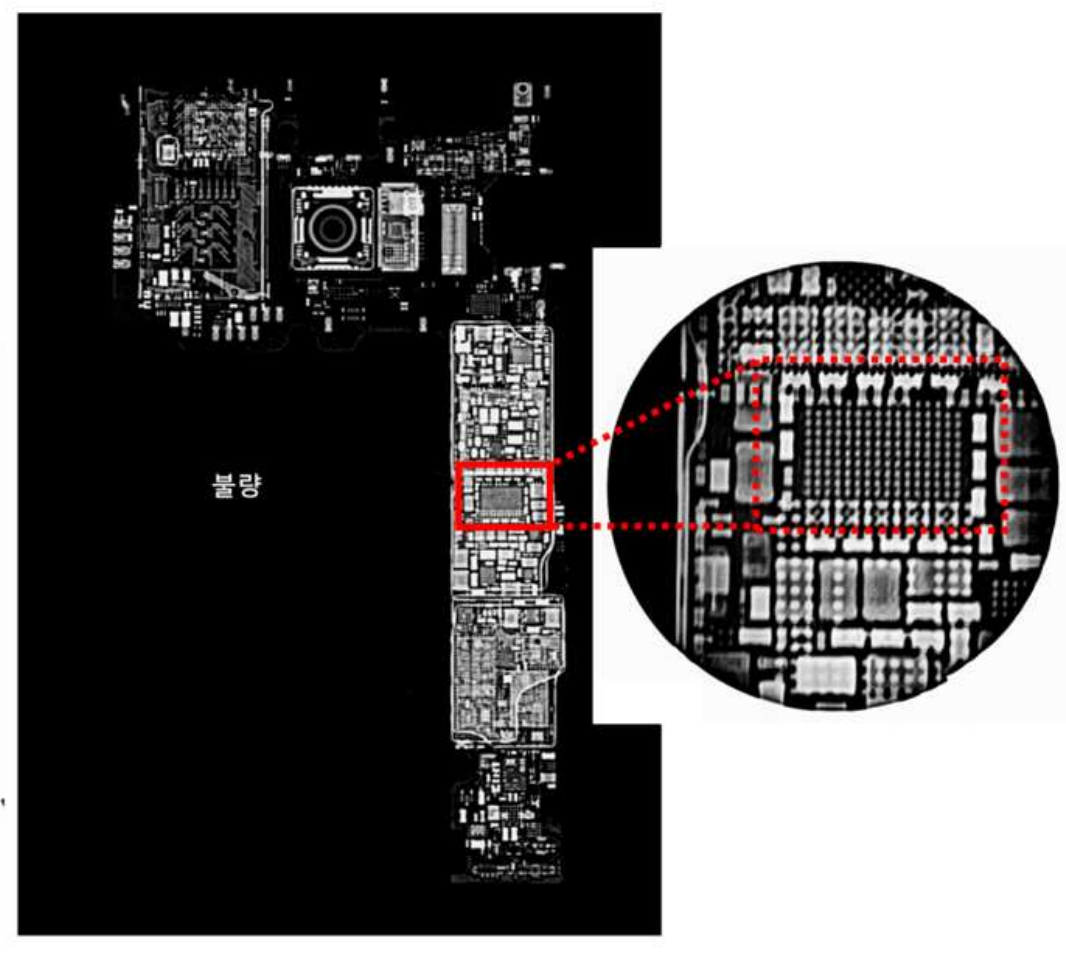
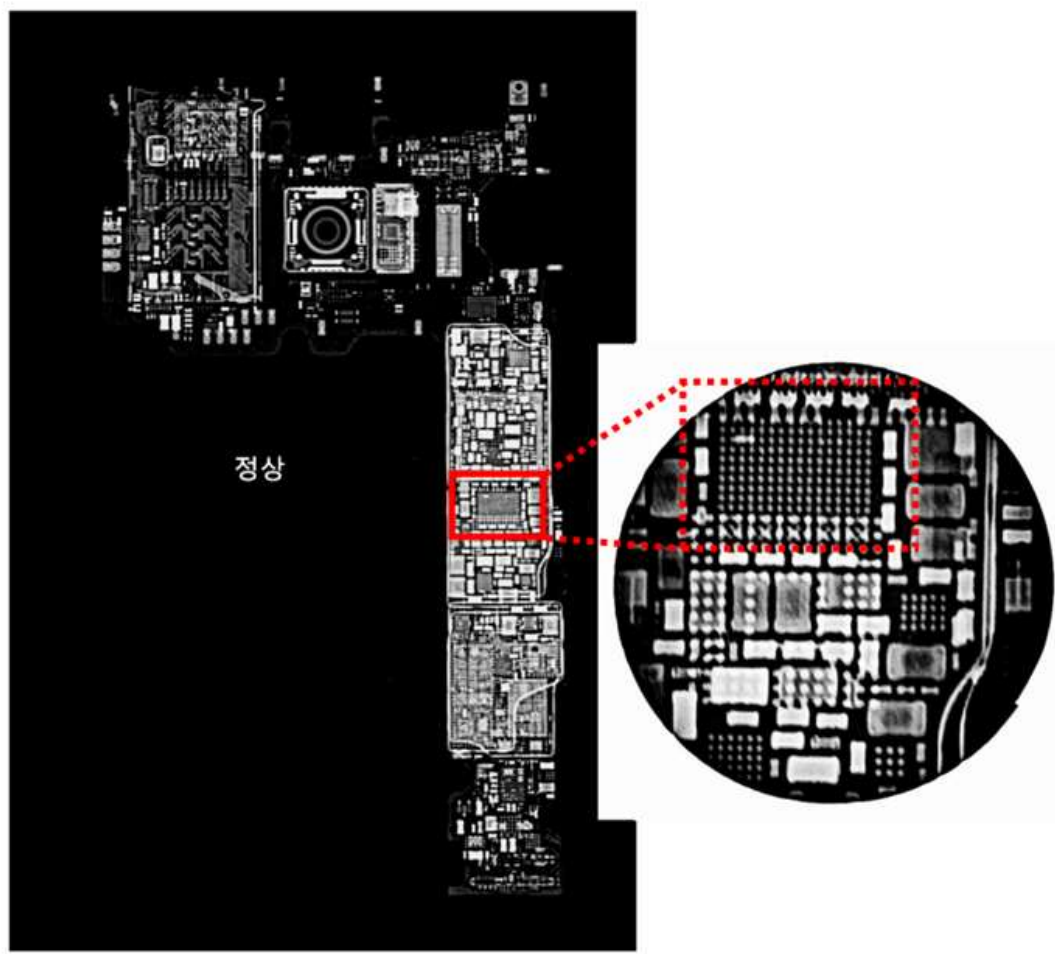

* 베가레이 촬영 이미지 - 스마트폰 카메라(아이폰 12)

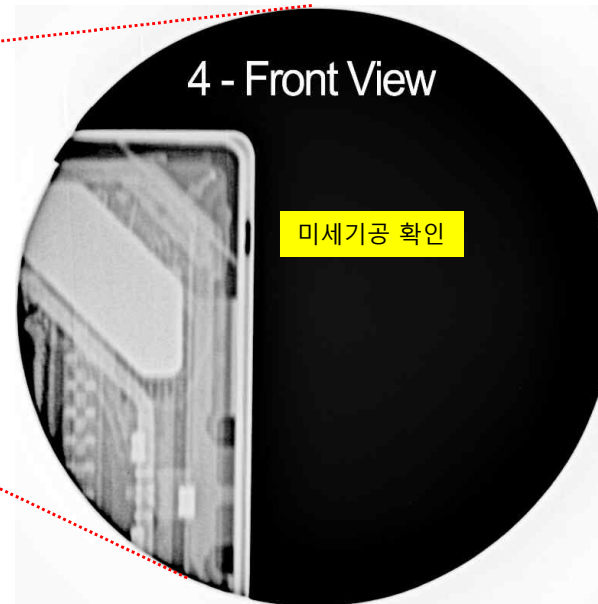
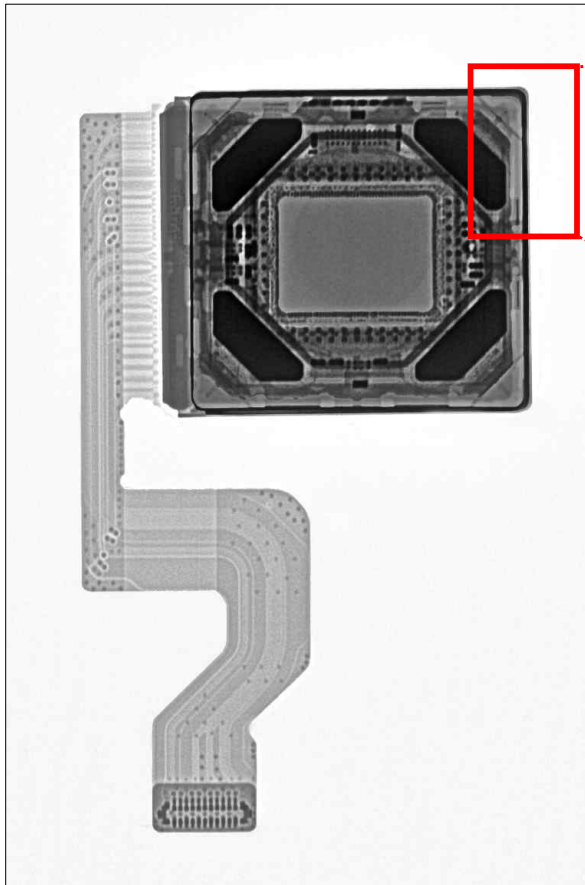

X-Ray for Electronic Components

* 베가레이 촬영 이미지 - 퓨즈

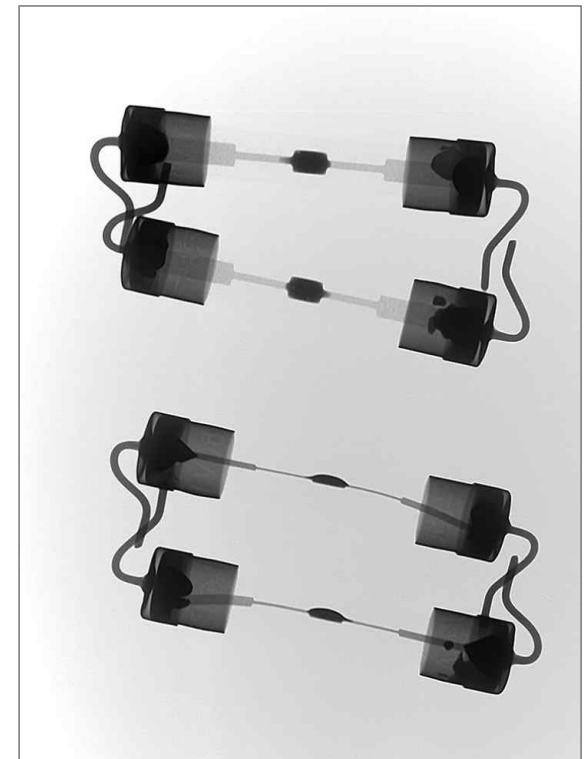
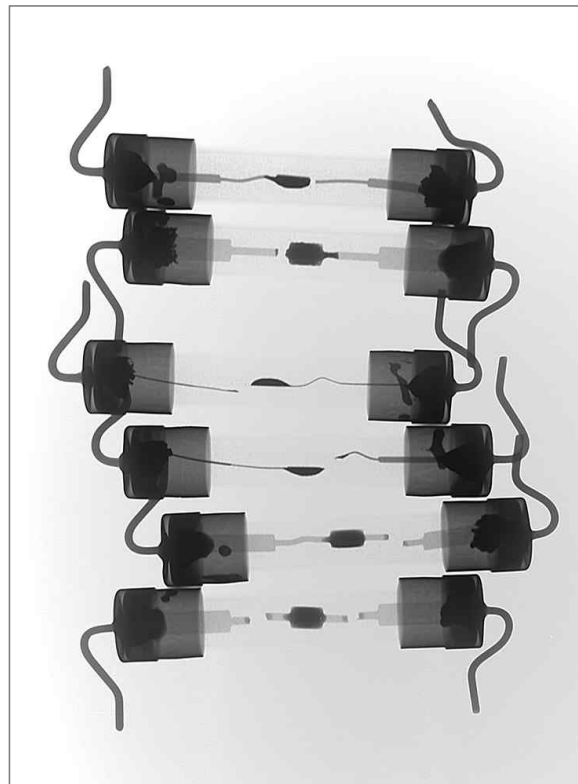
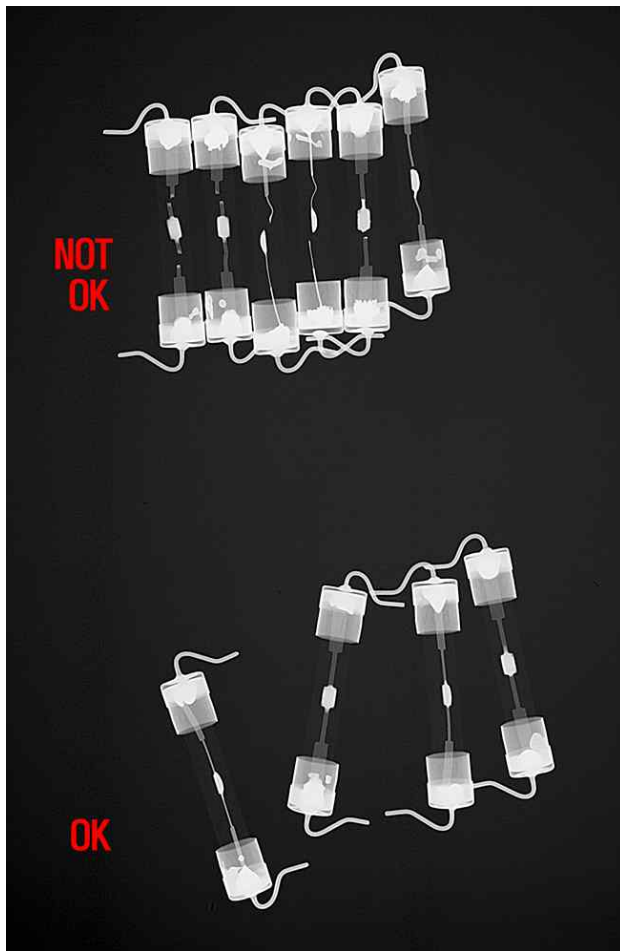

* 베가레이 엑스레이 촬영 이미지 - 접착면 확인

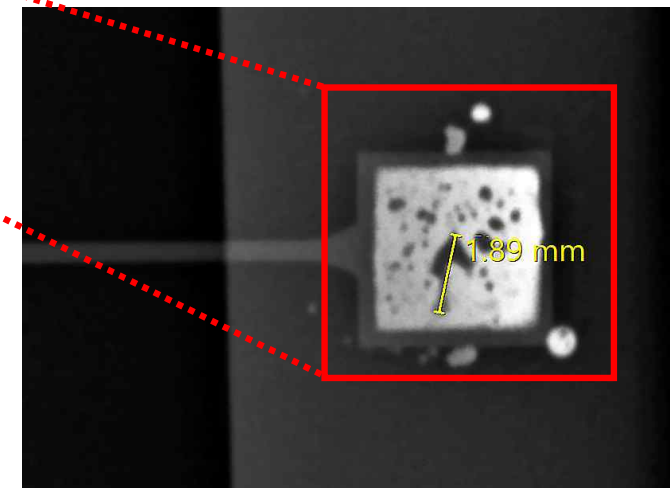
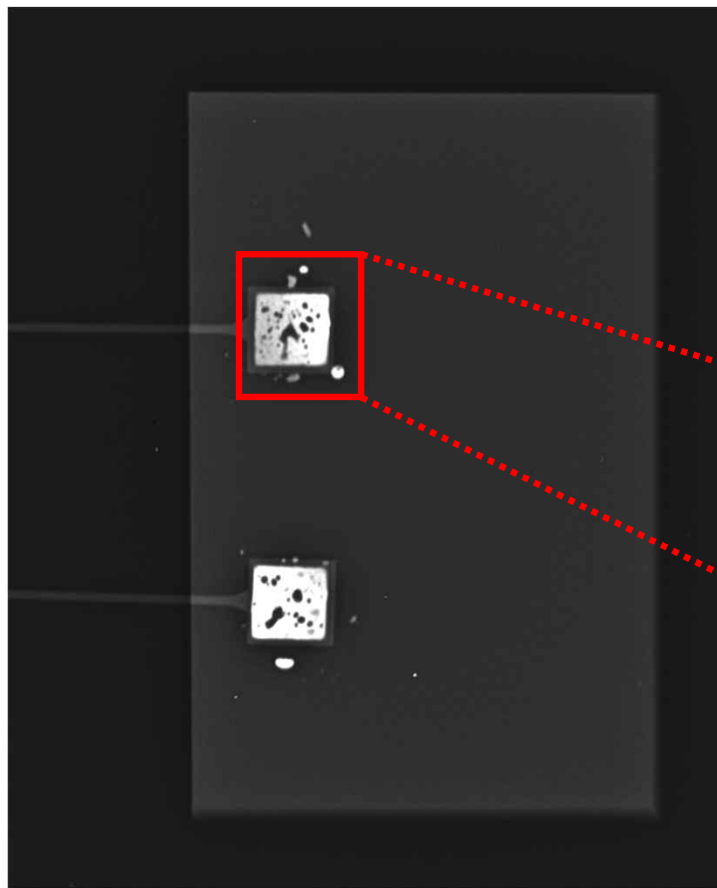
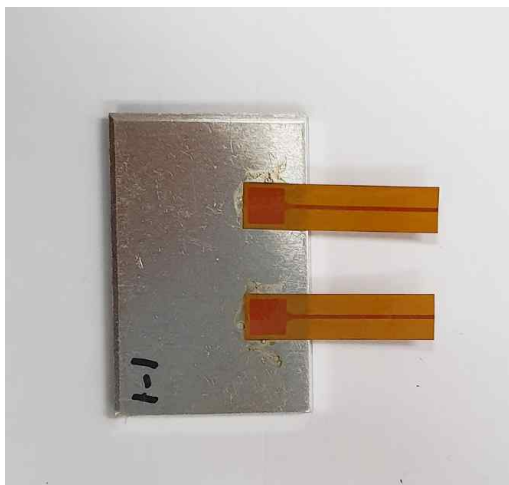

확대 - 1.89mm 기공 확인

* 베가레이 엑스레이 촬영 이미지 - 트랜스 부품 내부 사이즈 측정

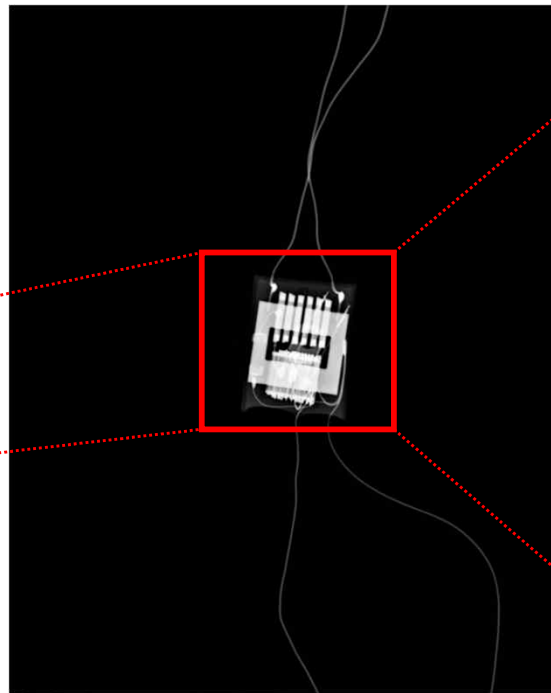
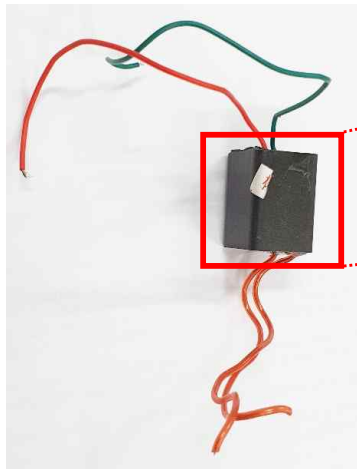

* 사이즈 측정

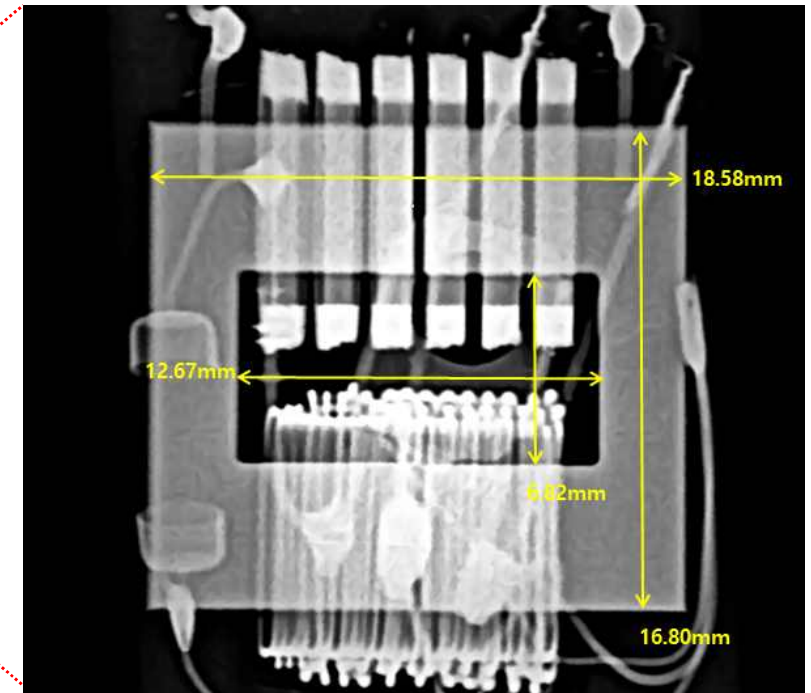

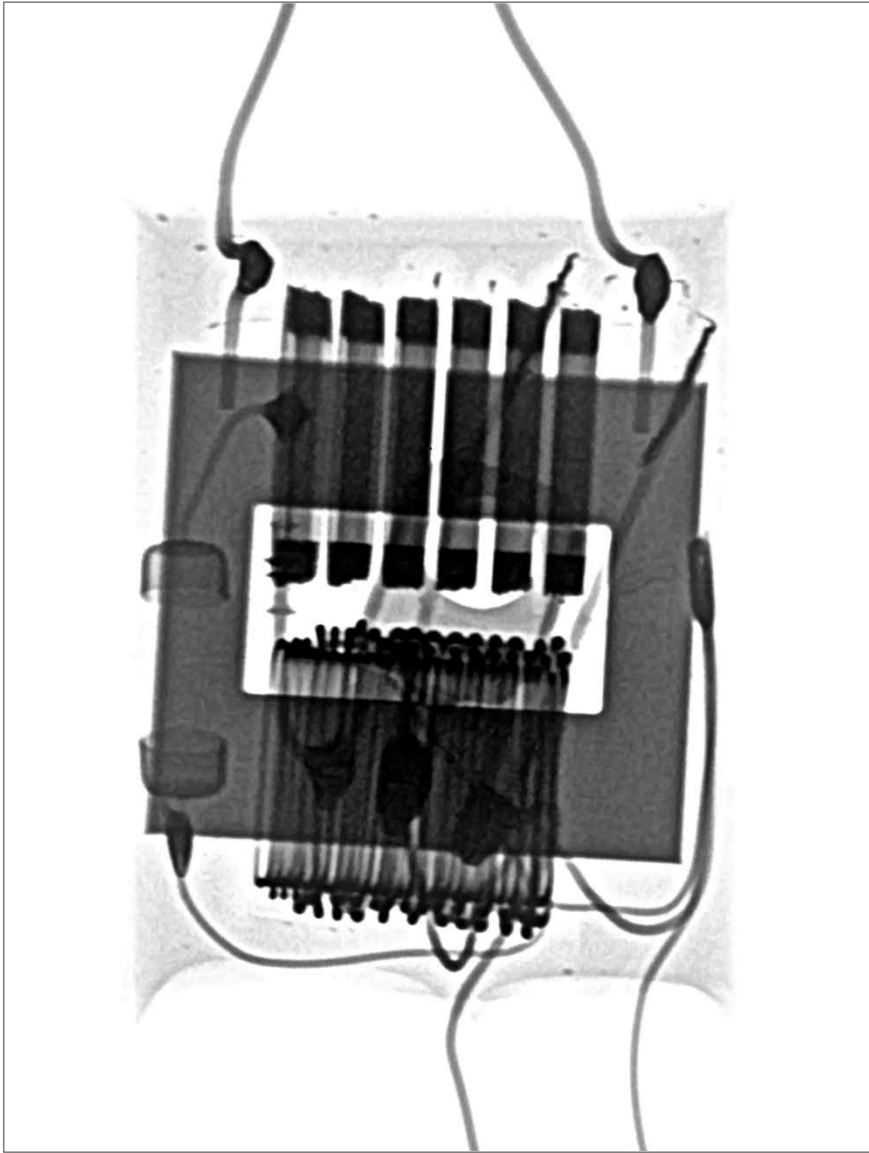

Side view



Top view

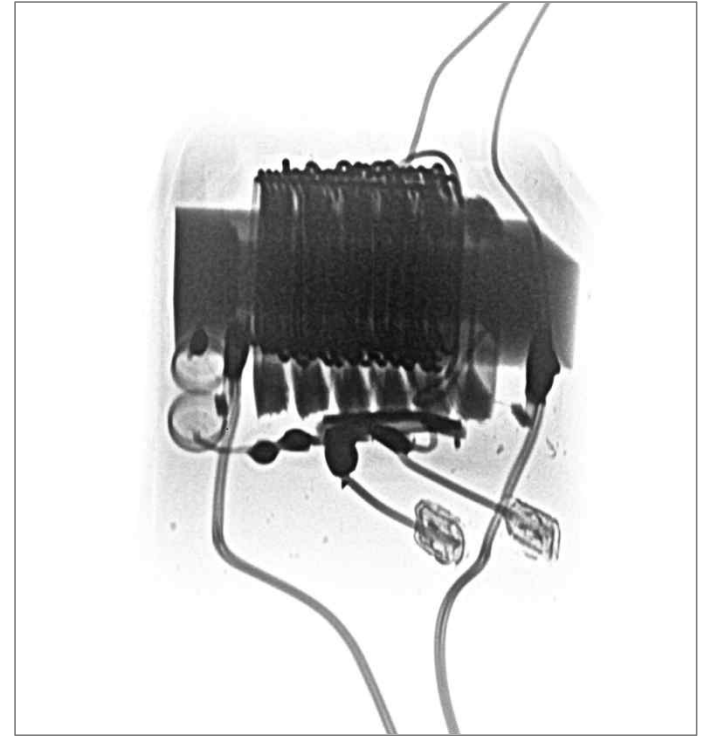

* 베가레이 촬영 이미지 - 히터 내부

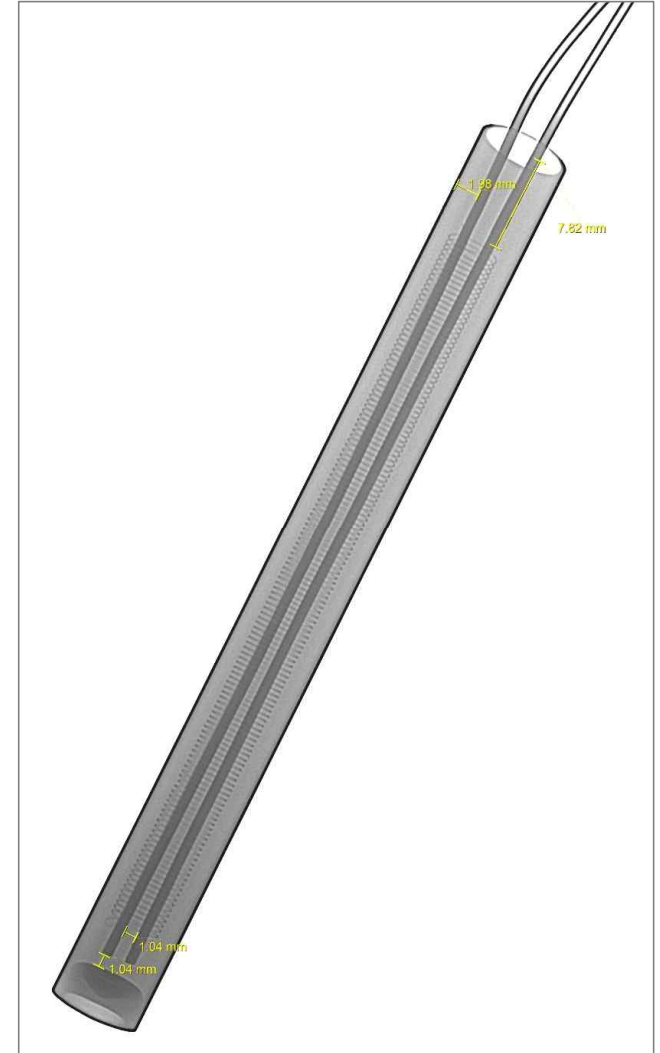
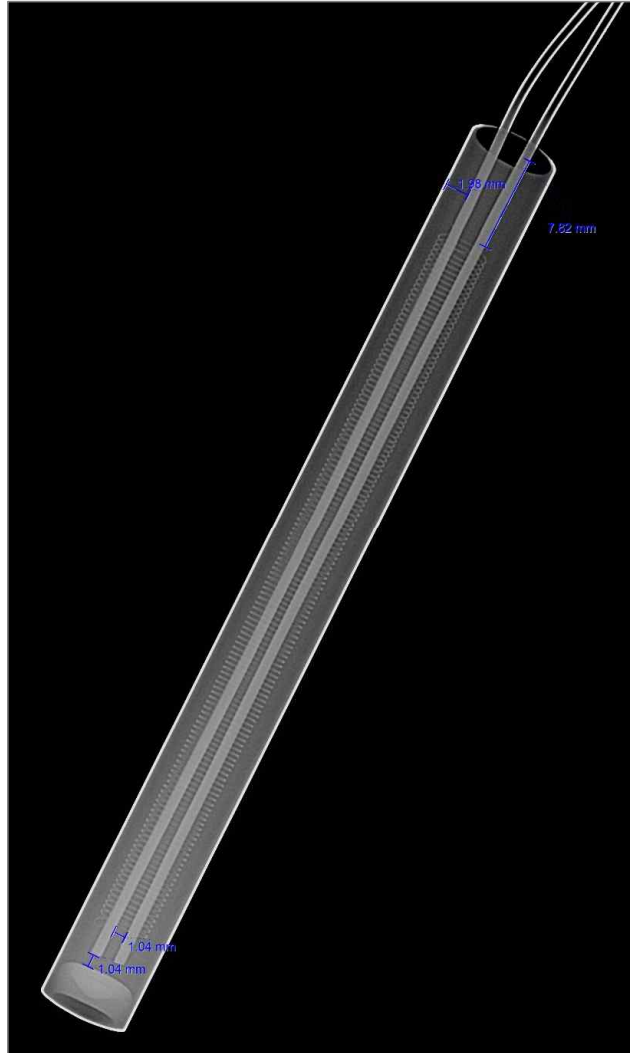

X-RAY on my desk

VEGARAY

X-Ray for Car Components

* 베가레이 엑스레이 촬영 이미지 - 알루미늄 부품



[반전 이미지]

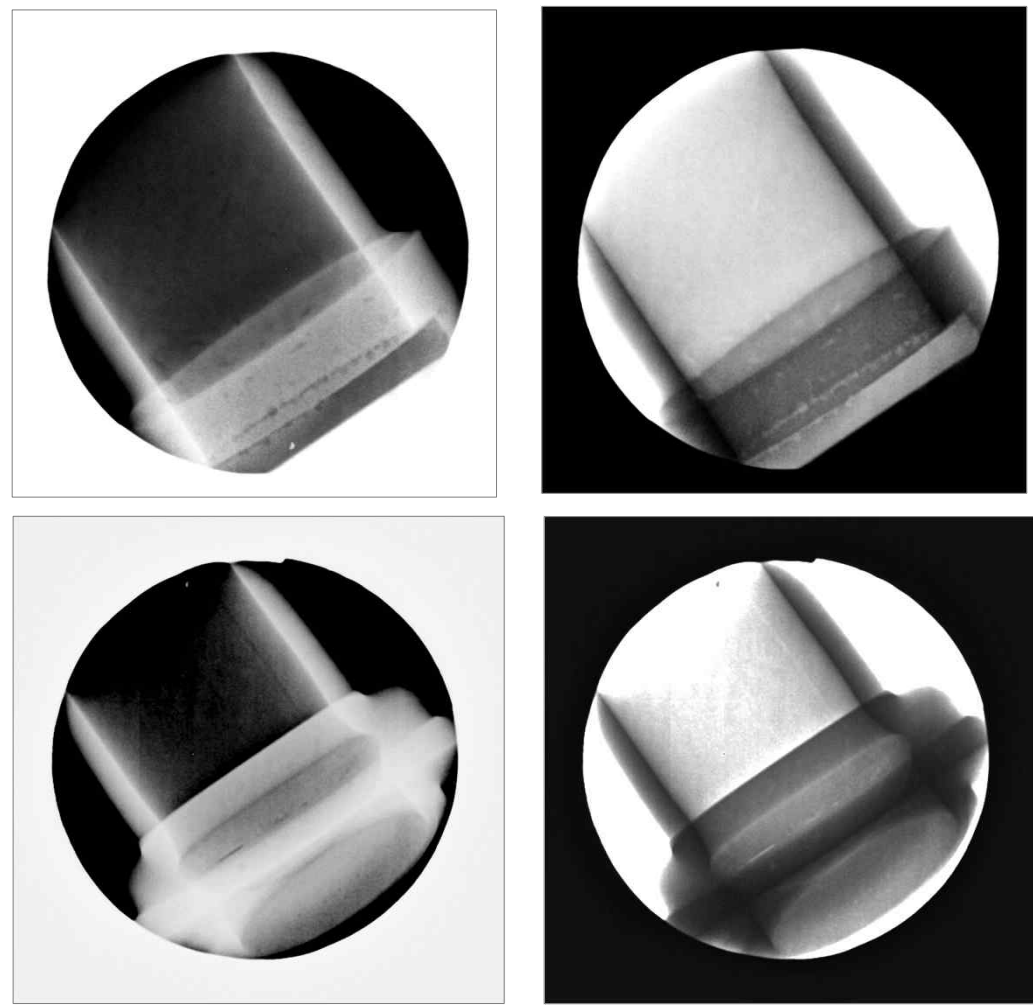

* 베가레이 엑스레이 촬영 이미지 - 자동차 부품 불량 확인

** 양품

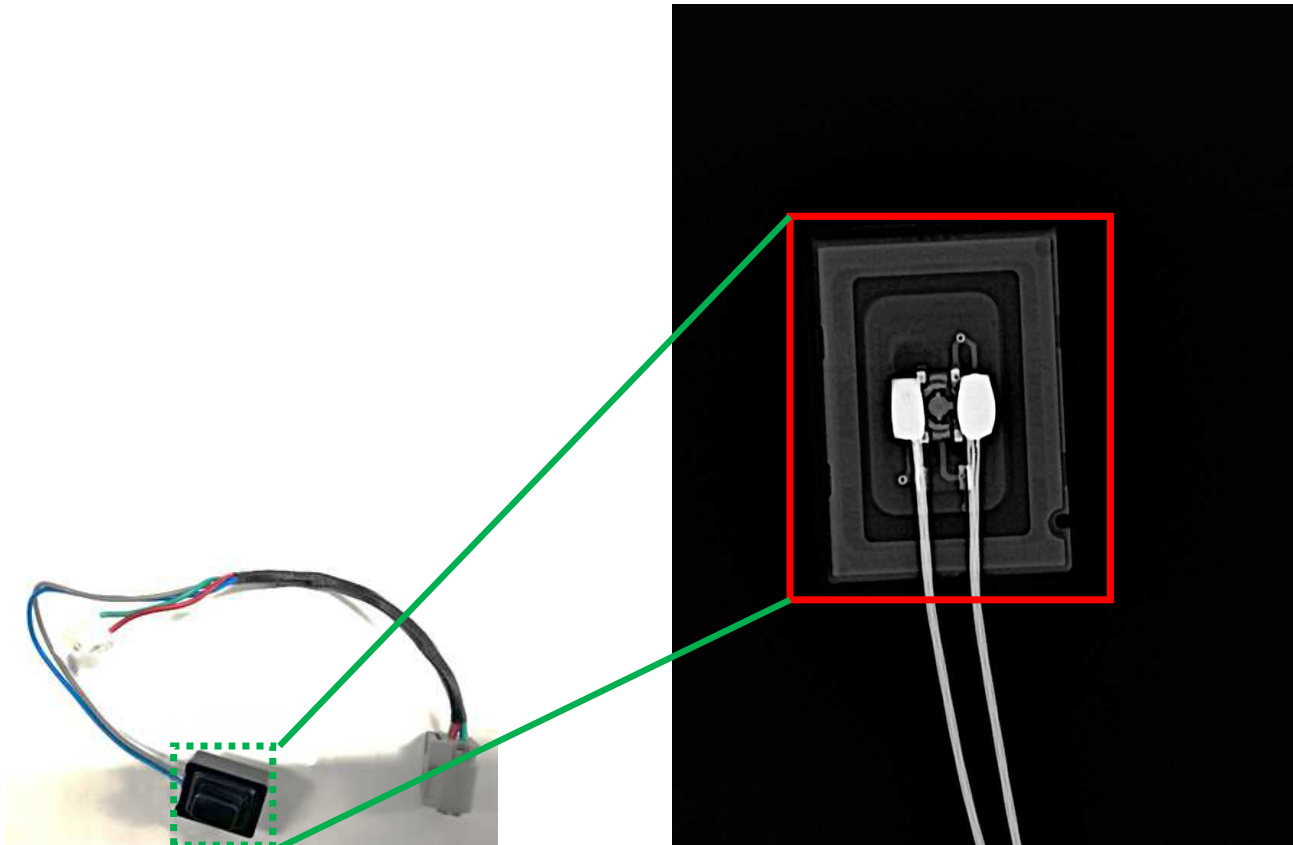

** 불량품 - 고정 링 이탈

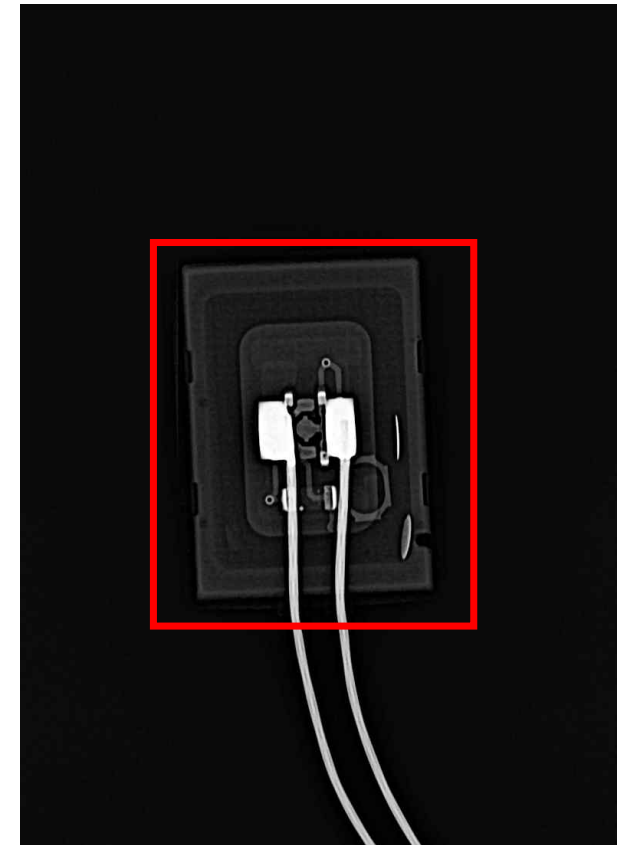

* 베가레이 엑스레이 촬영 이미지 - 자동차 부품 불량 확인

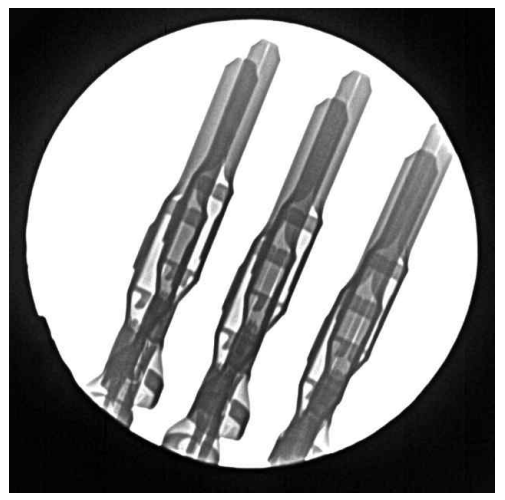
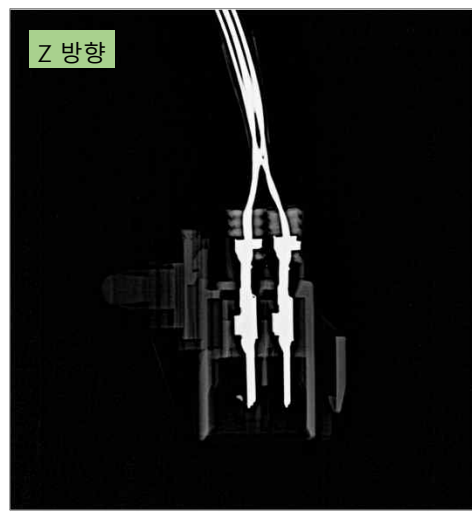
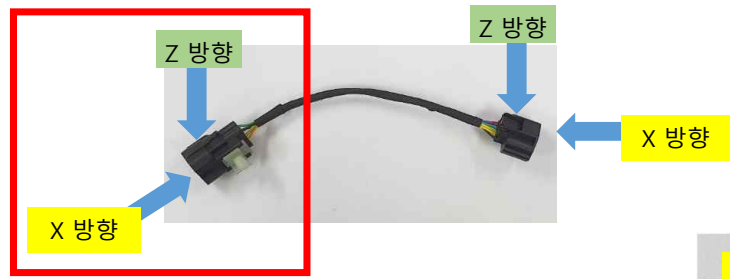

* 베가레이 엑스레이 촬영 이미지 - 자동차 부품 불량 확인

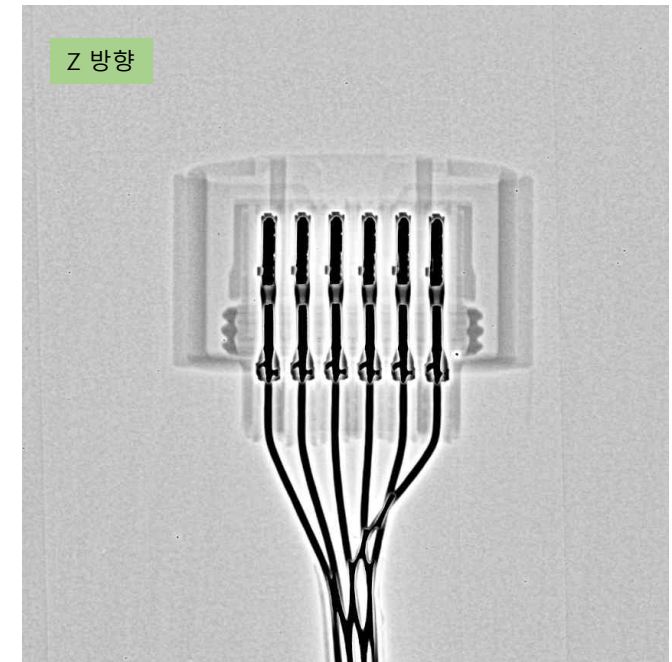
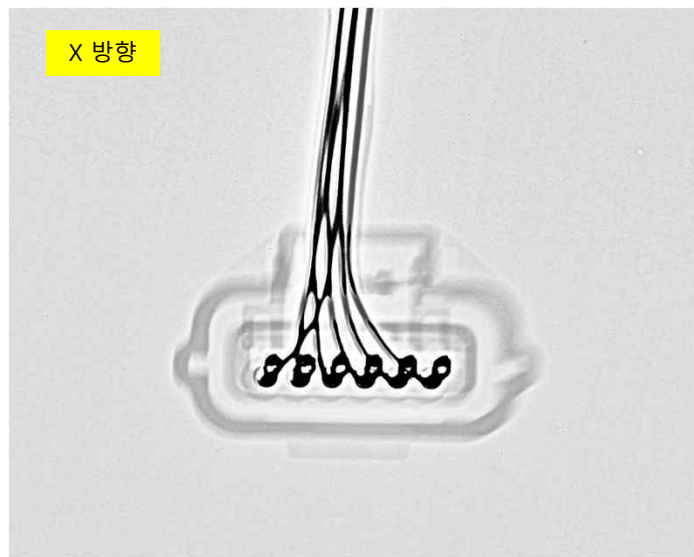
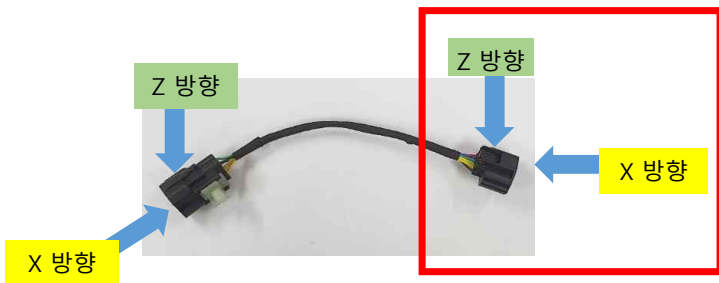

* 베가레이 엑스레이 촬영 이미지 - 자동차 부품 (코일 단선 확인)

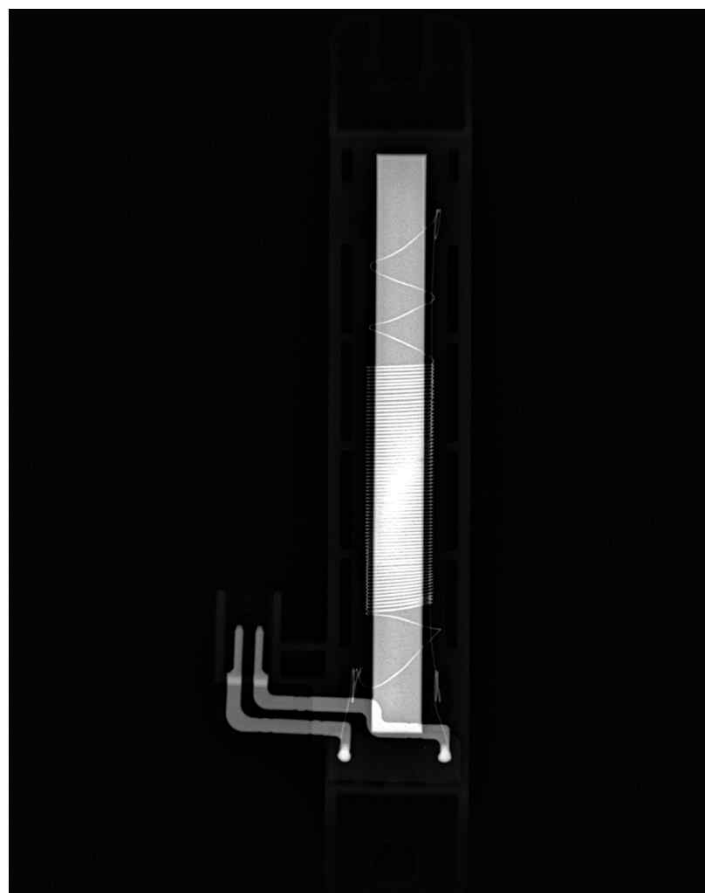

반전이미지



❖ 베가레이 엑스레이 촬영 이미지 - 인서트 사출 불량 검출

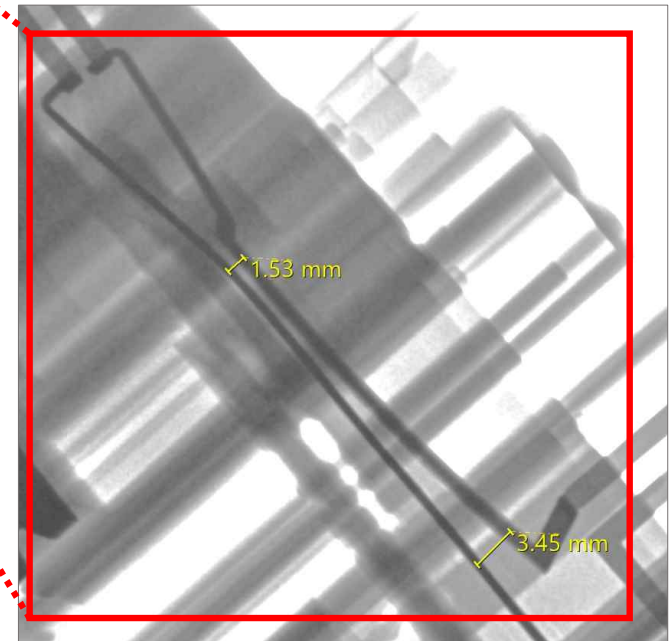
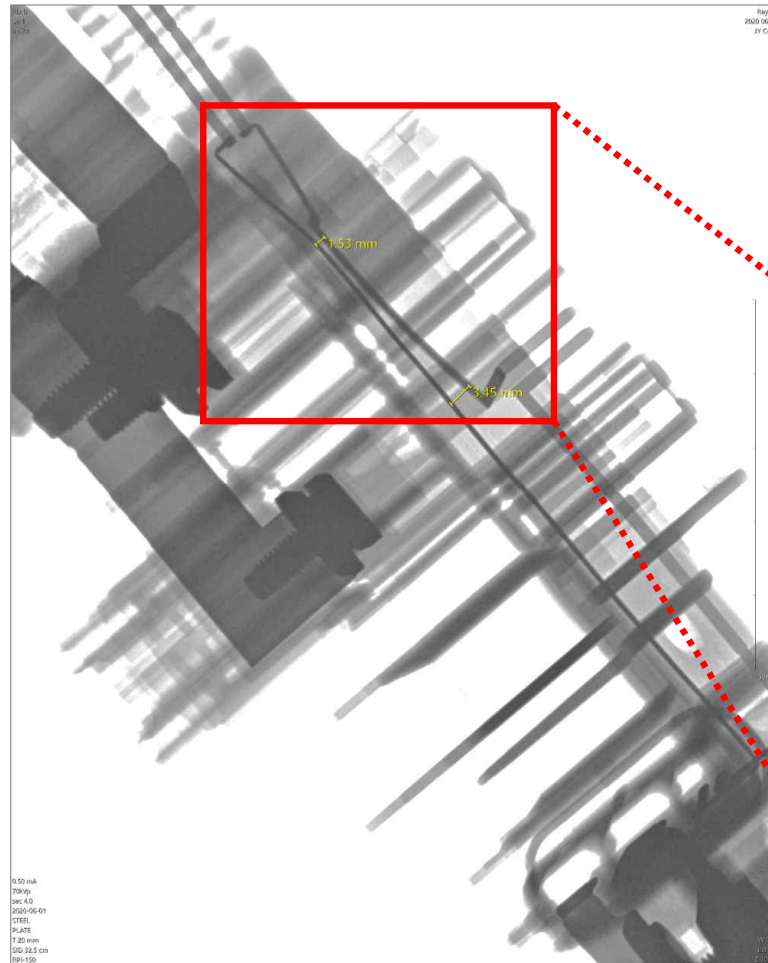
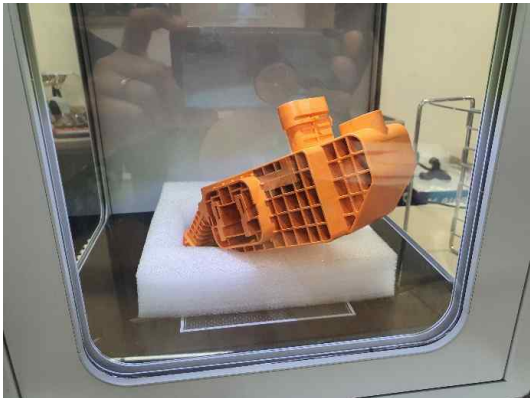

❖ 베가레이 엑스레이 촬영 이미지
- 자동차 사출 부품

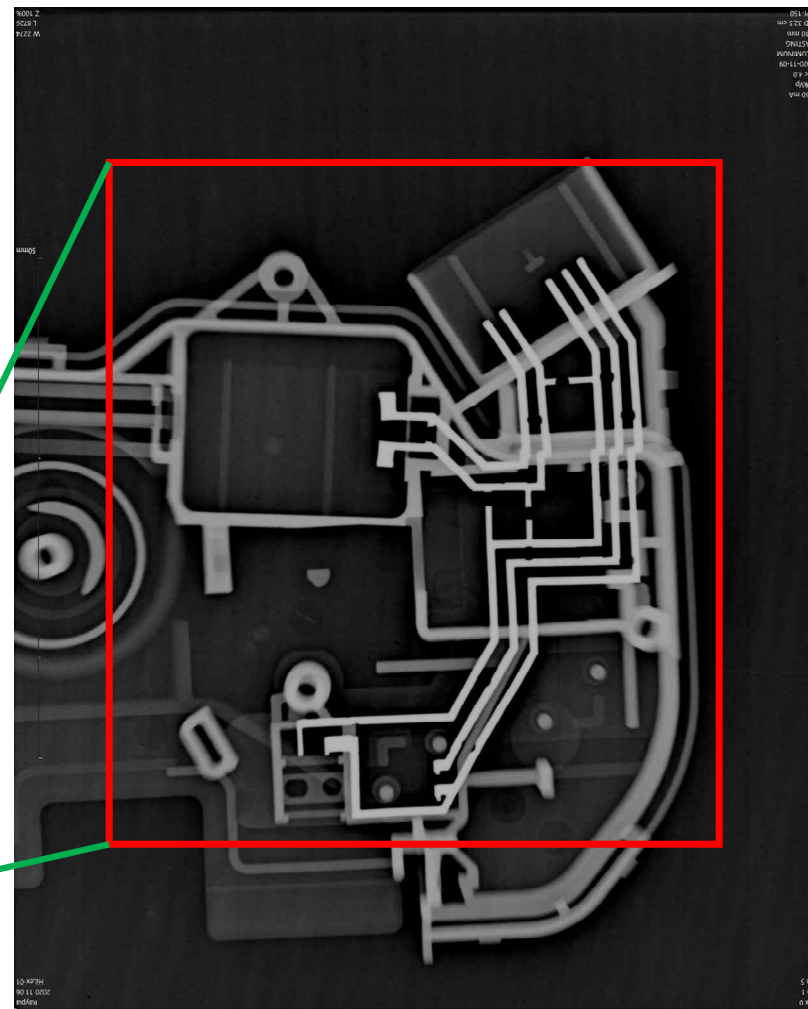
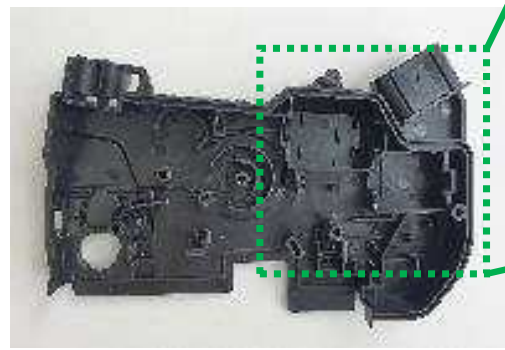

** 반전 이미지

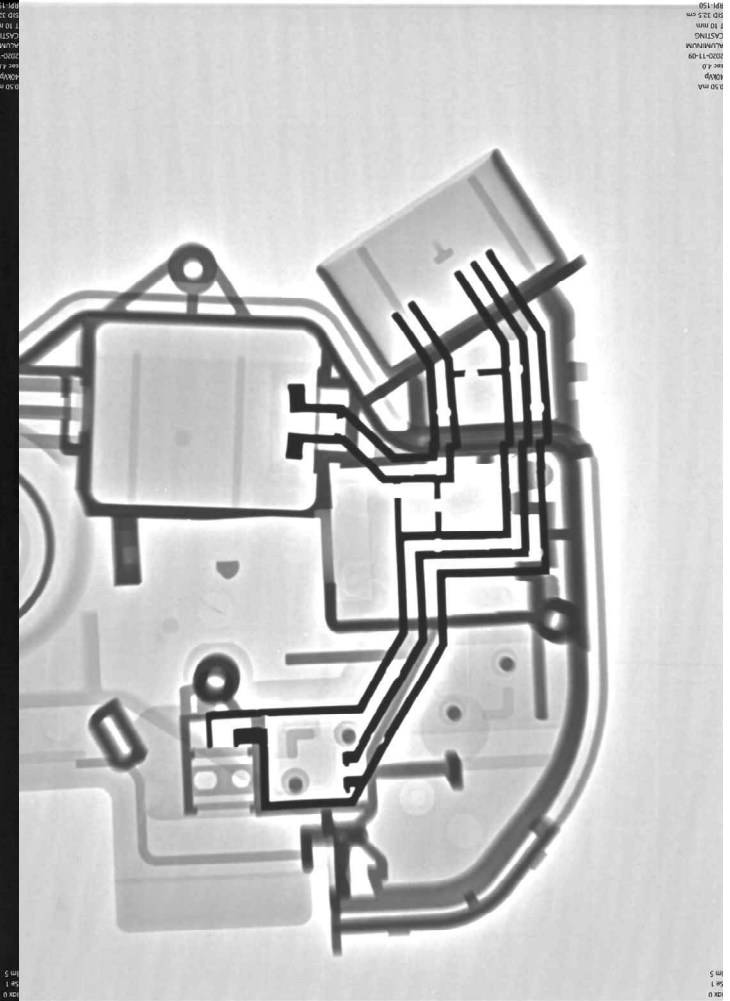

X-Ray for Plastic Parts

* 베가레이 엑스레이 촬영 이미지 - 플라스틱 사출 부품 기공 확인

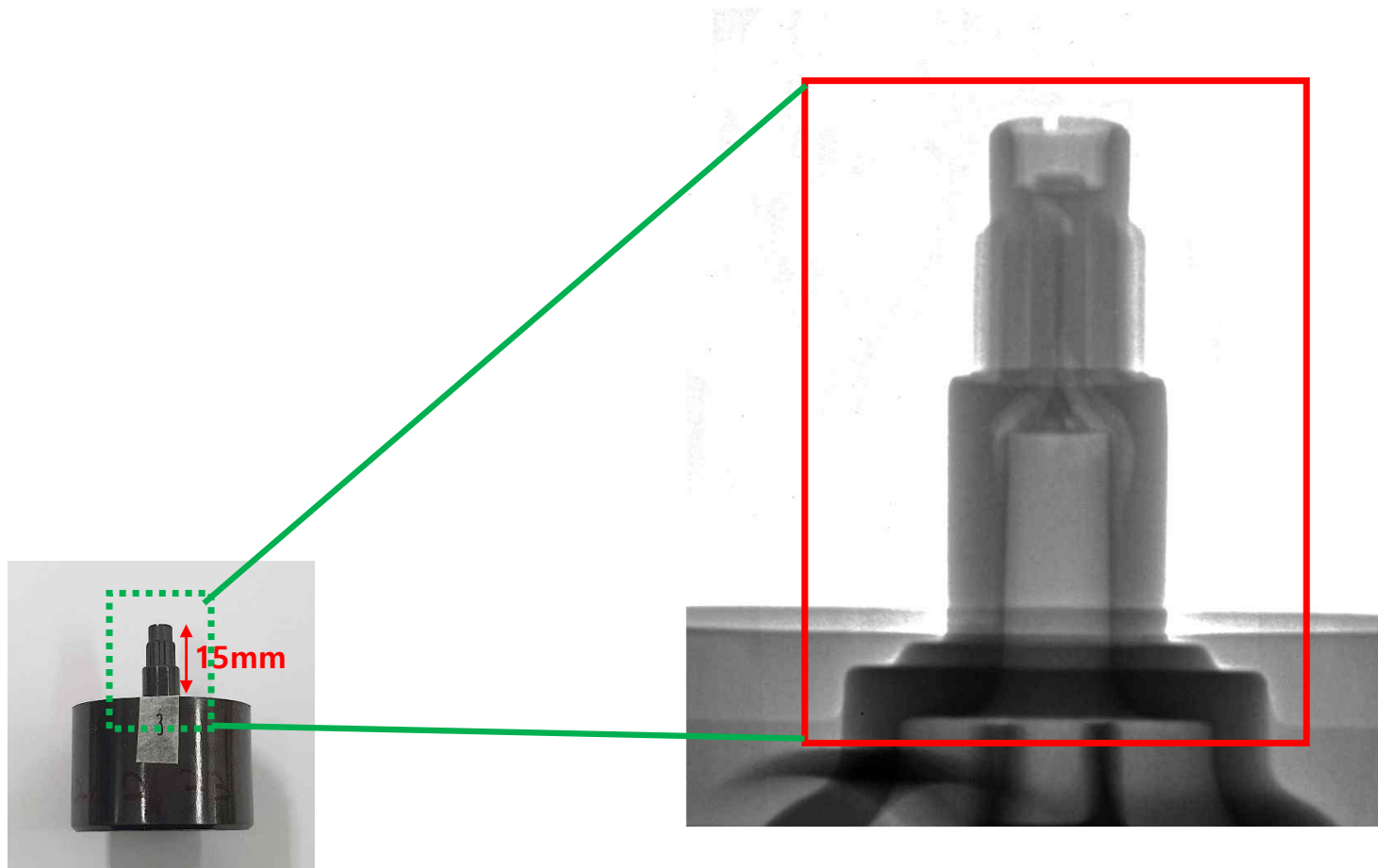

* 베가레이 엑스레이 촬영 이미지 - 플라스틱 사출 부품 기공 확인



* 베가레이 엑스레이 촬영 이미지 - 플라스틱 사출 부품 기공 확인

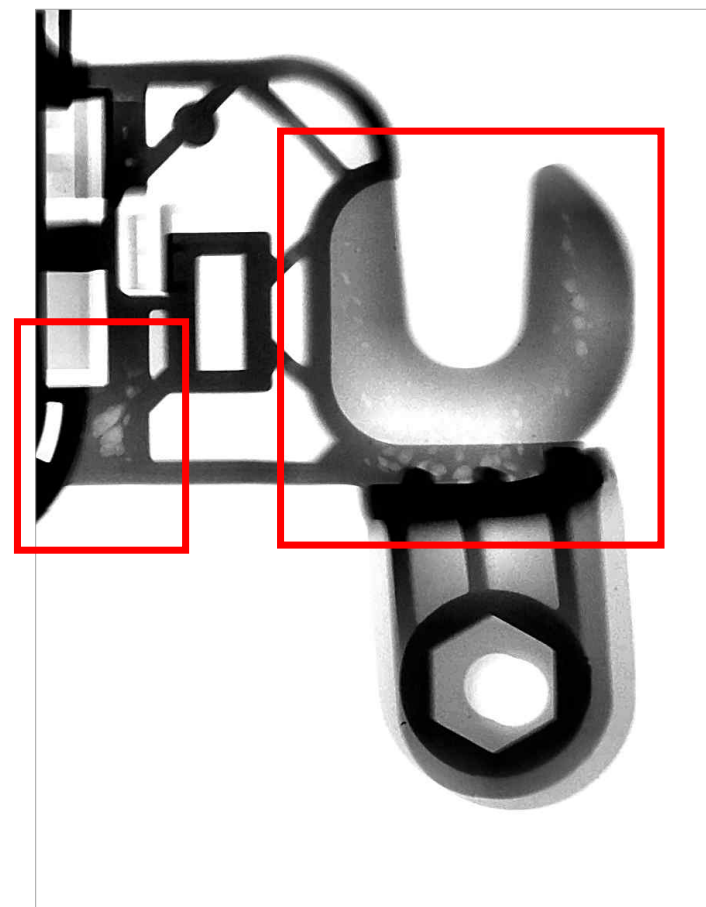
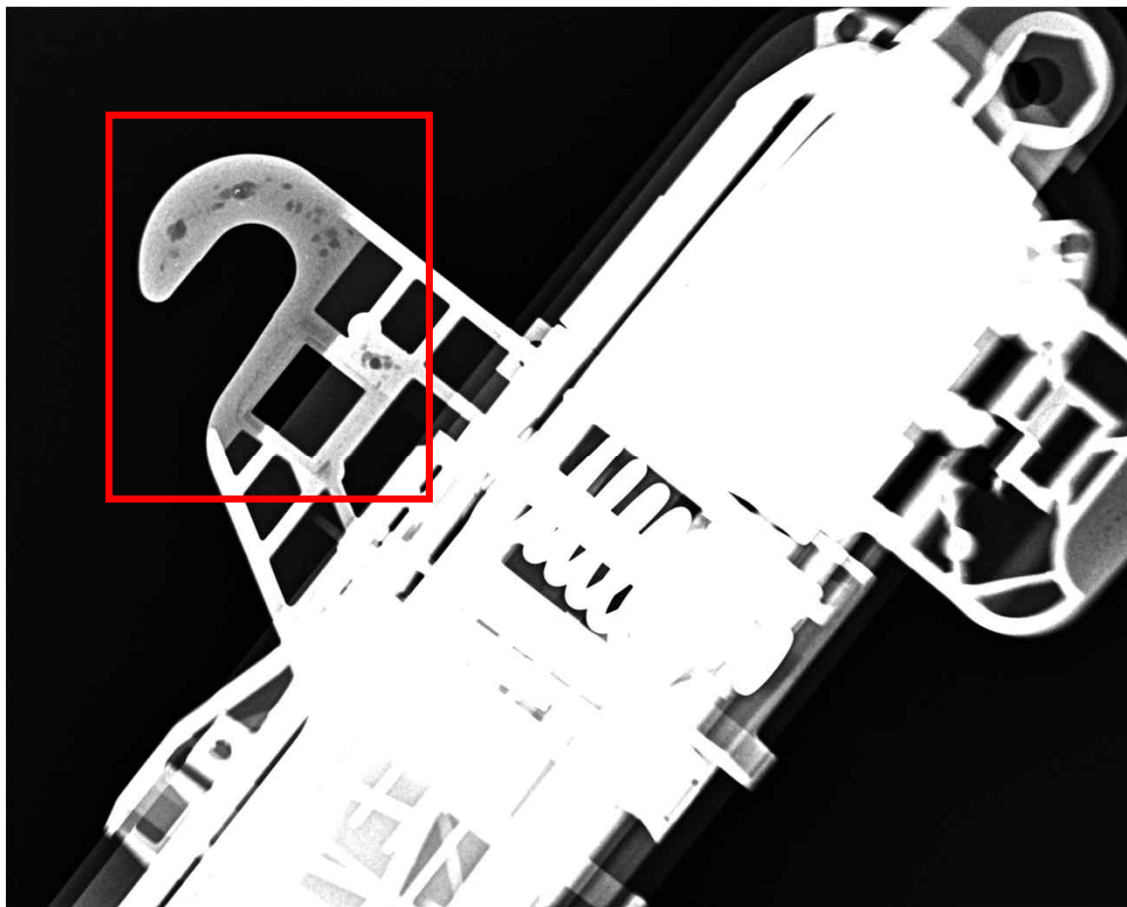

2. 베가레이 엑스레이 촬영 이미지

반전 이미지

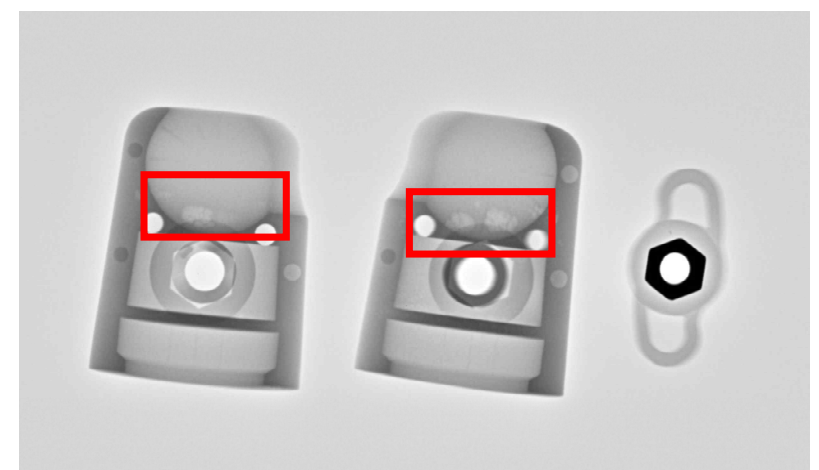
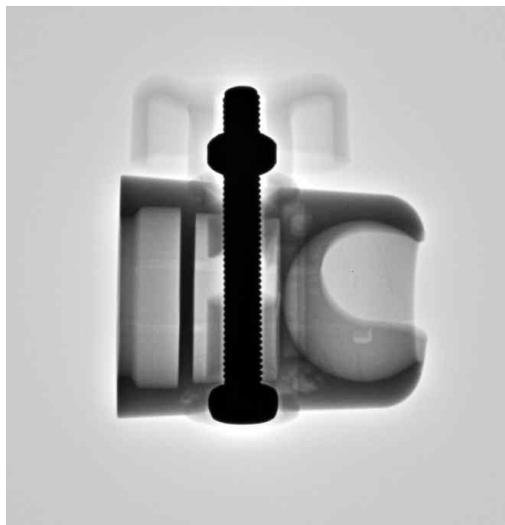
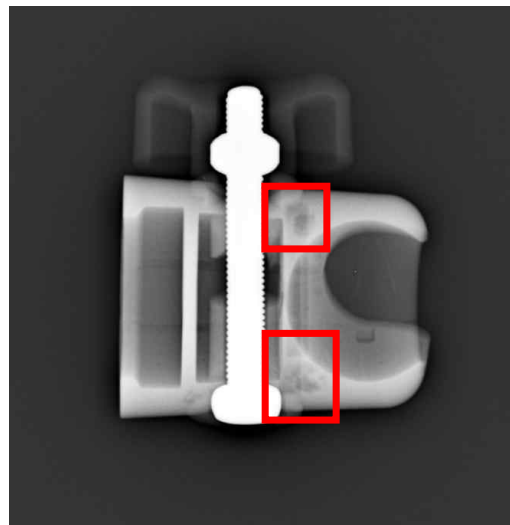
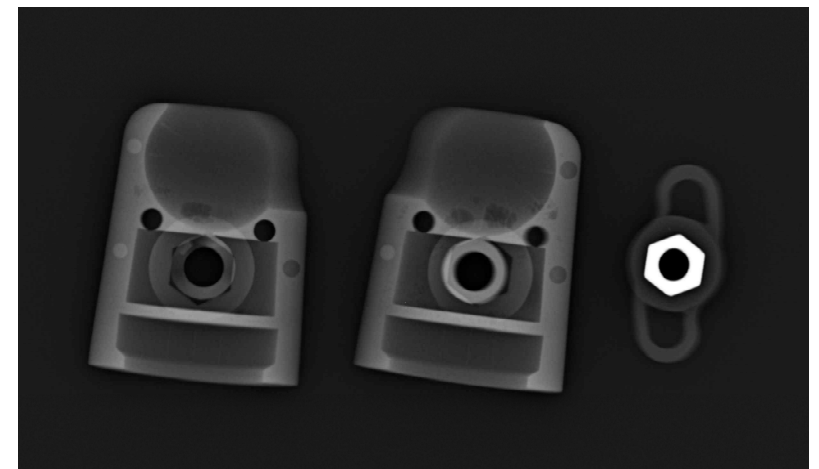
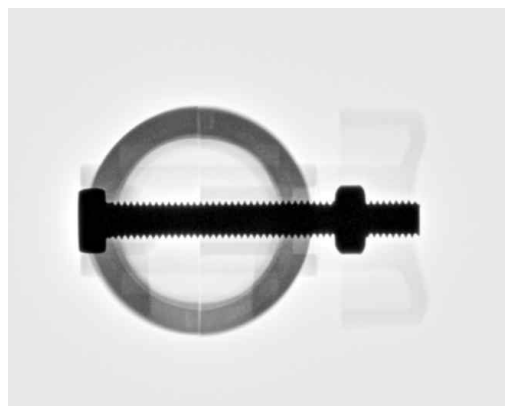
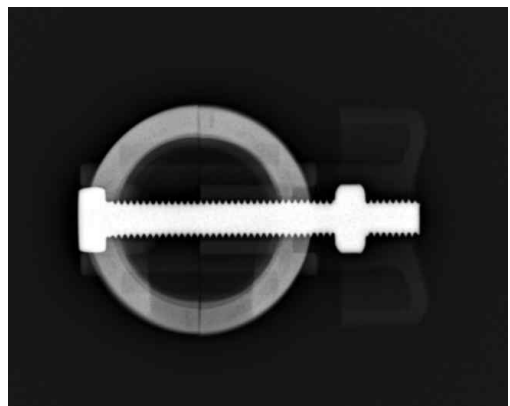

* 베가레이 엑스레이 촬영 이미지 - 플라스틱 사출 부품 기공 확인

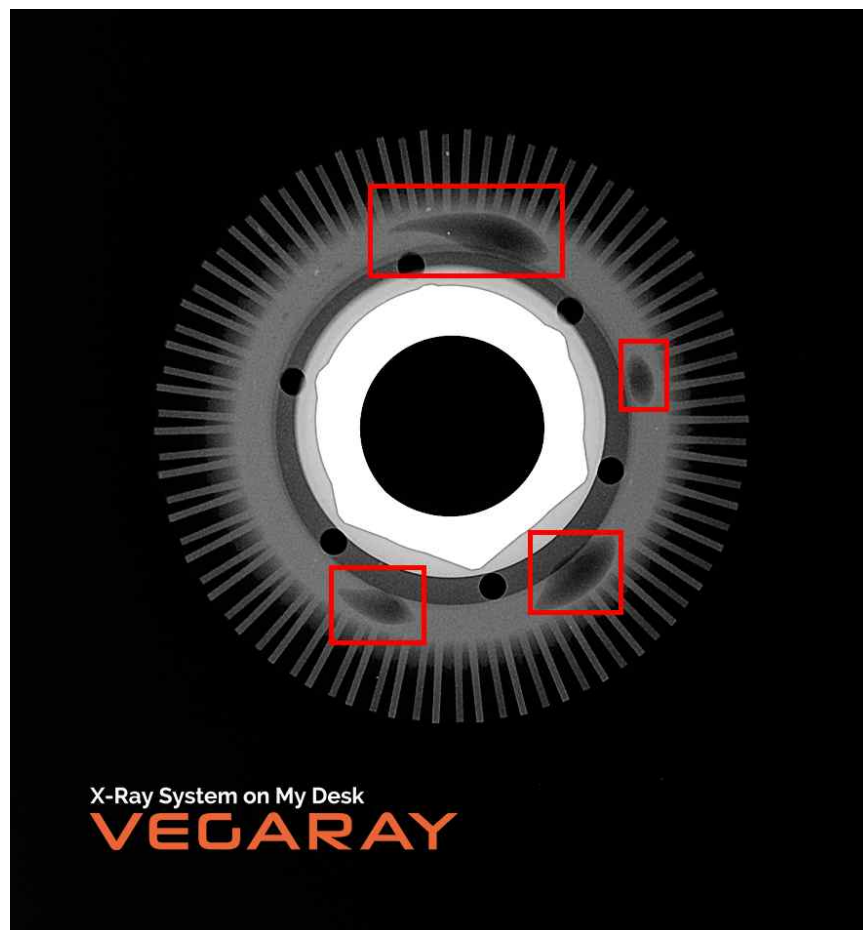

“

VEGARAY X-Ray는 컴팩트한 사이즈로
어디서나 빠르고 쉽게 결함이나 내부를 확인하는
가성비가 뛰어난 장비입니다

”



“

”

VEGARAY PRO

2023년 출시 예정



“VEGARAY PRO”

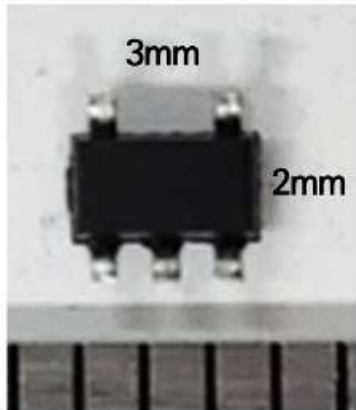

출시 예정 베가레이 프로 촬영 이미지

5 ~ 10um gold wire 식별 가능



VEGARAY

엑스레이 소개





VEGARAY 제품 특징

SAFETY & EFFICIENT

- 원자력안전위원회의 승인된 합법적 제품(원자력안전법 시행령 제7조~14조 방사선기기의 설계 및 구조에 관한 기준 적용)
- 방사선 누설 없는 완벽한 차폐 Cabinet (원자력안전법 시행령 제17조, 제19조 적용)
- 국내 기술의 독자개발

MOVING X-RAY

- 전용 캐리어를 이용한 이동 가능 제품
- 프리미엄을 담은 케이스 : 방수, 방진, 충격에 강함 / 케이스 후면에 확장 가능한 핸들 장착 / 스테인리스 스틸 베어링과 강한 폴리우레탄 바퀴 장착

REAL TIME X-RAY

- 실시간으로 빠르고 쉽게 X-ray 영상 획득
- 촬영된 영상을 활성화된 SW에서 획득, 이미지 컨트롤 가능

World Most COMPACT Cabinet X-Ray

- 캐비닛 타입 엑스레이 중 세계 최소형
- 사무실, 연구실, 공장 등 책상 위 작은 공간으로 충분
- 작지만 완벽한 차폐 & 최고의 성능





VEGARAY 구성과 스펙

General Specs.		VEGARAY_CL(캐비닛형)	Remarks
Weight		39Kg	
Voltage	Min	40kV	1kV adjustable
	Max	70kV	
Current	Min	0.1mA	0.01mA adjustable
	Max	0.5mA	
Time	Min	0.1sec	0.1sec adjustable
	Max	4.0sec	
Max Power		35W	
Display Method		LCD display	
Dimension		320(W) x 370(L) x 500(H) mm	
Power Supply		90-250 free Voltage	
X-Ray Tube	Model	OX/80-0.15	
	Focal Spot	0.15mm	
	Target Angle	19°	
Digital Flat Panel Sensor (Detector)	Type	CMOS Photodiode Array	
	X-Ray Converter	CsI:Tl/Gd2O2S:Tb	
	Effective Area	116 x 145 mm / 170 x 230 mm	
	Max. Sample Loading	20Kg	
	Pixel Pitch	49.5 μm	
Number of Active Pixels		2352 x 2944 / 2200 x 3050	
Resolution		10lp/mm	

No.	이름	설명
①	전원 Key switch	기기의 전원을 켜고 끄는 열쇠입니다.
②	LCD display	기기의 상태 및 전압, 전류, 조사시간을 알려주는 LCD 디스플레이입니다.
③	시료 넣는 문	시료를 넣는 문으로 열리면 엑스선이 발생되지 않고 문이 닫혀야 엑스선이 발생합니다.
④	디지털 센서	본체의 바닥에 고정되어 부착되어 있으며 엑스선이 발생되면 영상을 캡처하여 PC로 보내줍니다.
⑤	비상정지 버튼	비상시에 버튼을 눌러 기기를 멈추게 합니다.
⑥	경광등	엑스선이 발생하는 동안 경광등이 작동하며 시각적으로 사용자에게 경고를 알립니다.
⑦	전압 up/down 버튼	전압을 올리고 내릴 수 있습니다.
⑧	전류 up/down 버튼	전류를 올리고 내릴 수 있습니다.
⑨	조사시간 up/down 버튼	조사시간을 늘리고 줄일 수 있습니다.
⑩	핸드스위치	엑스선을 조사할 때 이 핸드스위치를 이용합니다.



VEGARAY 케이스 2종(별도 판매)

[펠리컨 케이스]



[테이블 겸용 케이스]





VEGARAY NDT Software

“촬영 즉시 영상 확인, 실시간 영상 조정”
간편한 사용자 인터페이스 / 다양한 영상 처리 기능 / 바로 보고서 작성 및 출력 가능

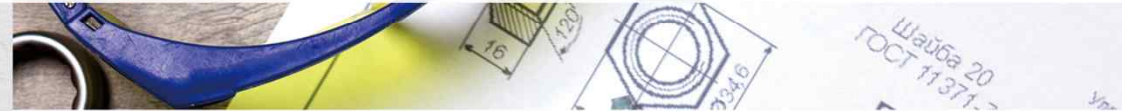

VEGARAY NDT S/W 주요기능



Emboss
영상의 값을 기준으로 영상에 양각 효과를 적용,
영상을 입체감 있게 표현합니다.



Length & Calibration
영상에서 발견한 결함부위의 크기를 측정하고
그 값을 보정할 수 있습니다.

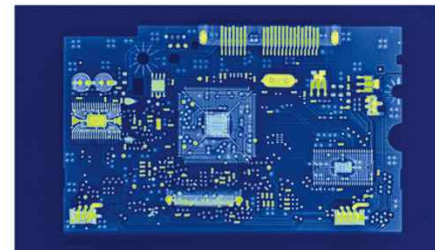

Pseudo Color
영상 농도에 따라 컬러를 맵핑, 서로 다른 물질인
지 확인 하는데 활용할 수 있습니다.

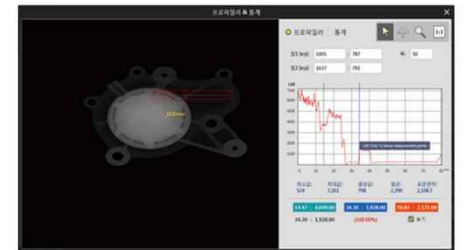

Line Profile
지정한 영역의 선 안의 픽셀 정보를 확인하고 그
값의 통계치를 확인할 수 있습니다.



SAFE X-RAY

완벽한 차폐, 안전을 먼저 생각한 X-RAY

공기 중 검출되는 자연 방사선 수치와 동일 (국가 환경 방사선 감시망 기준 서울시내 방사선 수치 0.11~0.14 $\mu\text{Sv/h}$)



1 Time Exposure 0.00013mSv/h

엑스레이 작동 중 나오는 방사선 수치 원자력안전법 기준 1/100 수준 (원자력 안전법 시행규칙 제 66조 2항)

* 0.13 $\mu\text{Sv/h}$ = 0.00013 mSv/h * 1 $\mu\text{Sv/h}$ = 0.001 mSv/h

VEGARAY 1538회 촬영 = 홍부 엑스레이 1회 촬영



1 Time Exposure
0.00013mSv/l

[기타 안전장치]

- * 비상정지버튼 - 화재 혹은 지진과 같은 천재지변 발생시 즉시 장비의 작동을 멈출 수 있습니다.
- * 인터락 시스템 - 문이 열린 상태에서는 버튼을 눌러도 X-RAY가 조사되지 않습니다.



VEGARAY 주요 고객사





회사 개요 및 인증

회사명 : 주식회사 레이피아
 설립 일자 : 2016년 2월 5일
 주요사업 : 엑스선 촬영장치 제조, 판매 (산업용, 진단용)
 본사주소 : 서울시 강서구 양천로 강서 한강 자이타워 A- 512
 대표전화 : 02-2658-1053 (팩스: 02-2658-2053)
 이메일 : info@raypia.com
 홈페이지 : www.vegaray.co.kr

원안위 생산허가증	원안위 설계승인서	특허증	디자인등록증	ISO 9001	CE
 <p>방사선발생장치생신허가증</p>	 <p>방사선기기설계승인서</p>	 <p>특허증</p>	 <p>디자인등록증</p>	 <p>CERTIFICATE Quality Management System</p>	 <p>CERTIFICATE</p>

감사합니다
Thank you



| 대표이사 | 김 창 수

경남 창원시 의창구 중동 784-1 어반브릭스 오피스동 1508호(15층)
Mobile. 010-9663-4509 / **E-mail.** tdk.cskim@gmail.com



| 영업/서비스 | 선 우 영 욱

경남 창원시 의창구 중동 784-1 어반브릭스 오피스동 1508호(15층)
Mobile. 010-9706-2718 / **E-mail.** tdk.swyw@gmail.com



The Dream Korea Blog

PARTNERSHIP



(주)더드림코리아 - VEGARAY 부산, 경남 대리점